

Research Article

Therapeutic benefits of music in reducing psychological anxiety

Meng Zhang¹ and Yoon Fah Lay²

¹Faculty of Social Sciences and Liberal Arts, UCSI University, Kuala Lumpur, Malaysia (ORCID: 0009-0005-2089-3787)

²Faculty of Psychology and Education, Universiti Malaysia Sabah, Kota Kinabalu, Malaysia; Faculty of Social Sciences and Liberal Arts, UCSI University, Kuala Lumpur, Malaysia; School of Liberal Arts and Sciences, Taylor's University, Kuala Lumpur, Malaysia (ORCID: 0000-0002-5219-6696)

The objective of this study was to ascertain the efficacy of music therapy in alleviating anxiety among university students. This is achieved by employing the theory of planned behaviour. A survey comprising 350 participants was disseminated to evaluate their subjective norms, perceived behavioural control, attitudes, intentions to engage, and actual involvement in music therapy, as well as their degrees of anxiety. The information gathered was examined using structural equation modelling. The findings validated that favorable attitudes, robust subjective standards, and elevated perceived behavioral control fostered students' inclination to engage in music therapy. In addition, it is unsurprising that students who intended to participate ultimately followed through and carried out the task. The structural equation modelling analysis ultimately demonstrated that engaging in these sessions significantly decreased students' levels of anxiety. While effective in the examined context, the research acknowledges geographic and demographic limitations, suggesting the need for broader investigations. This study adds to the growing evidence supporting the integration of music therapy into mental health services, particularly for university students facing academic stressors.

Keywords: Music therapy; Psychology; Theory of planned behavior

Article History: Submitted 14 January 2024; Revised 13 May 2024; Published online 7 June 2024

1. Introduction

Researchers and academics have long been intrigued by the complex connection between music and human emotions. Music has a significant global impact that goes beyond artistic borders, affecting several facets of human experience (Mastnak, 2023). Recent developments in psychology research have provided additional insight into the substantial influence of music on emotional states, confirming its profound impacts (Gerstgrasser et al., 2023; Starcke et al., 2021). An increasing amount of evidence has prompted research efforts to investigate the healing capacity of music. Anxiety, which is characterized by physiological manifestations such as elevated blood pressure, heightened tension, excessive anxiety, and persistent rumination (Karki & Mahara, 2022), is notably widespread as a mental health issue. The alleged advantages of music in mitigating anxiety and stress present a compelling basis for scientific exploration in this field.

The purpose of this study was to fill a significant need for additional research by performing a quantitative investigation of the effects of music therapy on anxiety. Although medical

Address of Corresponding Author

Meng Zhang, Faculty of Social Sciences and Liberal Arts, UCSI University, 56000 Cheras, Kuala Lumpur, Malaysia.

✉ 1002162322@ucsiuniversity.edu.my

How to cite: Zhang, M. & Lay, Y. F. (2024). Therapeutic benefits of music in reducing psychological anxiety. *Journal of Pedagogical Research*. Advance online publication. <https://doi.org/10.33902/JPR.202427508>

interventions frequently achieve positive outcomes in addressing physical problems, the process of healing is complex and involves the overall mental well-being of the individual. This research stands out by utilizing innovative approaches that have not been previously employed in this area. Expanding on the increasing evidence, our study examines music therapy as a possible substitute for conventional anxiety therapies, which can be time-consuming and demanding (Landis-Shack et al., 2017). Although there are some anecdotal confirmations of the effectiveness of music therapy, it is necessary to conduct organized and quantitative research to validate these claims and develop a legitimate and empirical foundation.

Our objective is to improve the comprehension of music therapy to enable tailored and efficient treatment methods that are in line with patient preferences, thereby closing the divide between theory and application. This study aimed to not only enhance academic understanding but also to have a direct influence on clinical practice, providing vital insights for healthcare professionals in their everyday work.

2. Literature Review

2.1. Music Therapy and Its Psychological Implications

Music therapy, as an intervention for stress reduction, has garnered increasing attention in both medical and mental healthcare settings. In a significant meta-analysis, Witte et al. (2020) highlighted the medium-to-large effect of music therapy on reducing physiological and psychological stress-related outcomes. This finding underscores the distinctiveness of music therapy, which involves personally tailored music interventions by a qualified therapist, from mere music listening.

The role of music therapy extends beyond stress reduction, particularly in the field of pediatric oncology. Facchini and Ruini (2020) conducted a systematic review highlighting the feasibility and positive effects of music therapy on the mental and physical health of children and adolescents with cancer. This study also noted the variability in intervention strategies and study designs, indicating the need for more standardized approaches. In more specific medical procedures, such as hematopoietic stem cell transplantation, music therapy has shown promising results. Geyik et al. (2020) reported that music therapy significantly improved the physiological and psychological parameters of cancer patients, notably increasing oxygen saturation levels and reducing anxiety and distress. This emphasizes music therapy's role in enhancing patient well-being during intense medical procedures.

Furthermore, the impact of music therapy on mental health conditions such as schizophrenia is noteworthy. Salur et al. (2017) reported significant improvements in general functionality, emotional regulation, and personal and social performance in patients with schizophrenia following music therapy. These improvements highlight the potential of this therapy for managing complex mental health conditions. In addition, the conceptual framework of music therapy, as analysed by Murrock and Bekhet (2016), offered a deeper understanding of its therapeutic properties. Their work identifies what makes it work so well.

According to Legge (2015), music therapy has the ability to effectively control emotions from a neurobiological standpoint. Specifically, this approach applies to environments focused on mental health, such as hospitals. This perspective serves to reconcile disparities between psychological models. Furthermore, research has been conducted on stress markers. In a study conducted by Wong et al. (2021), it was discovered that music therapy effectively decreased stress indicators and psychological stress in acute scenarios.

The studies discussed above demonstrate the multifaceted impact of music therapy across different patient demographics and medical conditions, highlighting its potential for reducing stress, managing psychological disorders, and improving overall mental and physical health. The diversity of related research underscores the versatility of music therapy as a therapeutic intervention.

2.2. Psychological Anxiety: Definition and Impact

Psychological anxiety is a multifaceted emotional state often characterized by an unpleasant state of inner turmoil accompanied by nervous behavior such as pacing, somatic complaints, and rumination. As described by Hufnagel et al. (2017), fear is an emotional condition marked by fear, worry, and apprehension, where fear often dominates other emotions. Additionally, Alzahrani et al. (2017) emphasized that anxiety is not only an emotional response but also characterized by physical symptoms such as increased blood pressure, reflecting its psychosomatic nature.

The etiology of anxiety is diverse and encompasses environmental factors, genetic predispositions, and personal life experiences (Gottschalk & Domschke, 2017). Anxiety disorders, as classified in psychological diagnostic manuals, range from generalized anxiety disorder to more specific phobias, each presenting unique challenges in diagnosis and treatment. Therefore, the impact of anxiety extends far beyond the individual, affecting society at large. McEvoy et al. (2019) underscored the moderate association of intolerance of uncertainty, a trait commonly linked to anxiety, with symptoms of several psychological disorders. In further emphasizing the broader implications of these findings, Niknamian (2019) explored the connection between anxiety and physical health issues, including chronic conditions such as cancer. This correlation illustrates the profound effect that anxiety can have on overall health and well-being.

In terms of specific impacts, research by Irgebaeva and Akmusaeva (2020) indicated that increased levels of anxiety can lead to a significant decline in quality of life, highlighting the importance of effective management strategies in both clinical and therapeutic settings. Moreover, the recent COVID-19 pandemic, as reported by Luo et al. (2020), has had a substantial psychological impact on medical staff and the general public, exacerbating levels of anxiety and depression. This recent global health crisis has brought to the forefront the need for robust mental health support systems.

In addition, the economic implications of anxiety are also significant, encompassing healthcare expenditures and reduced productivity, further underscoring the need for effective and accessible treatment modalities (Nicolescu et al., 2024). In this context, the potential role of alternative therapies, such as music therapy, has become increasingly relevant (Tsisiris, 2017). These therapies offer promising avenues for addressing not only the emotional but also the physical manifestations of anxiety.

2.3. Empirical Studies on Music Therapy and Anxiety

Kenny and Halls (2018) explored the development of group interventions for music performance anxiety among community musicians. Utilizing cognitive-behavioral therapy and anxiety sensitivity reduction techniques, their study demonstrated an effective reduction in anxiety and an enhancement in performance quality, highlighting the adaptability of music therapy in addressing performance-related anxiety. In the realm of trauma and post-traumatic stress, Landis-Shack et al. (2017) provided a theoretical review of music therapy's application for adults with post-traumatic stress disorder. They delineated mechanisms such as community building and emotion regulation, underscoring its therapeutic potential in facilitating healing and anxiety reduction in trauma-exposed individuals. Witte et al. (2021) conducted a scoping review on creative arts therapies, including music therapy, for anxiety management. Their findings indicated a positive impact on psychological outcomes, reinforcing the broad scope of creative arts therapies in managing anxiety across diverse populations.

To focus on oncological settings, Dash (2017) assessed the impact of music therapy on cancer patients. Observing significant reductions in depression and stress, this study points to its potential as an adjunctive treatment in oncology by aiding in patients' psychological well-being while coping with cancer. On another note, Zang et al.'s (2023) meta-analysis investigated its effect on alleviating anxiety among cancer patients. Their results revealed a moderate reduction in cancer-related anxiety, suggesting its integration into palliative care.

In their study, Gutiérrez and Camarena (2015) proposed a methodical music therapy strategy for the treatment of generalized anxiety disorder, demonstrating its efficacy in diminishing symptoms. This finding indicates that this technique holds promise as a main or supplementary therapy for generalized anxiety disorder. Notably, Lund et al. (2016) described Aalborg University Hospital's project as methodically implementing sound and music in hospital settings to empower patients to select music that caters to their specific needs. They presented evidence supporting the role of this method in diminishing anxiety and promoting relaxation in clinical environments. Finally, Lu et al. (2021) offered a meta-analysis evaluating its efficacy on anxiety. Their study concluded that it significantly improved anxiety symptoms during treatment, emphasizing its effectiveness in clinical practice.

These studies collectively illustrate the effectiveness of therapy for reducing anxiety across various contexts and affirm its potential as a versatile and effective therapeutic intervention. A body of empirical evidence supports the use of music therapy in clinical settings and guides the development of targeted therapeutic protocols, paving the way for further research in this field.

2.4. Theoretical Framework and Research Model

The theory of planned behaviour (TPB), formulated by Icek Ajzen in the late 1980s, has been shown to be highly valuable in elucidating human behaviour. This is particularly true in circumstances linked to health. It distinguishes itself from other theories by emphasizing the influence of cognitive and social elements on decision making and behaviour. The fundamental principle of the TPB is that an individual's actions are driven by his or her intention to carry out those activities. The formation of this intention is influenced by three factors: the individual's attitude toward the behaviour, subjective norms, and perceived behavioural control (Ajzen, 1991).

We selected the TPB for our study because of its proven effectiveness in health psychology, specifically in comprehending the factors influencing individuals' decisions regarding health behaviours. This approach is essential for investigating choices pertaining to therapy and treatment. According to Lok (2013), 'Attitude' in the TPB framework refers to an individual's overall appraisal of participation in music therapy, which includes both positive and negative evaluations. This encompasses views regarding the effectiveness of music therapy in the management of anxiety and emotional responses toward receiving such therapy. 'Subjective norms' pertain to the perceived influence or backing from important individuals, such as family, friends, or healthcare practitioners, with regard to participation in music therapy (Bae & Chang, 2021). The concept of 'perceived behavioural control' pertains to an individual's perception of the level of ease or difficulty accessing and engaging in music therapy, taking into account logistical, personal, and situational aspects (Nayanajith & Damunupola, 2020). Figure 1 illustrates the framework of this theory.

According to our model, depicted in Figure 2, the variable 'Intention to Engage in Music Therapy' (abbreviated as Intention) plays a crucial role as a mediating factor. It is situated at the intersection of cognitive perceptions (attitudes, subjective norms, and perceived behavioural control) and the concrete act of participating in music therapy. This statement aligns with TPB's claim that intention is the primary and direct indicator of behaviour, serving as the connection between thoughts and actions. The hypothesis posits that the crucial factor in an individual's active participation in music therapy sessions is the strength and direction of their purpose, which is influenced by the three TPB components discussed earlier. Progressing past the stages of intention and involvement, our study model concludes by analysing anxiety levels as the last outcome variable. In line with the utilization of the TPB in several health behaviour studies, our objective is to assess the fluctuations in anxiety levels resulting directly from participation in music therapy (referred to as engagement). Anxiety levels will be measured using validated psychological evaluation techniques, enabling us to scientifically examine the impact of music therapy. This approach not only aligns with the theoretical foundations of the TPB but also guarantees that the evaluation of results is based on dependable and validated procedures.

Figure 1
Theory of planned behaviour

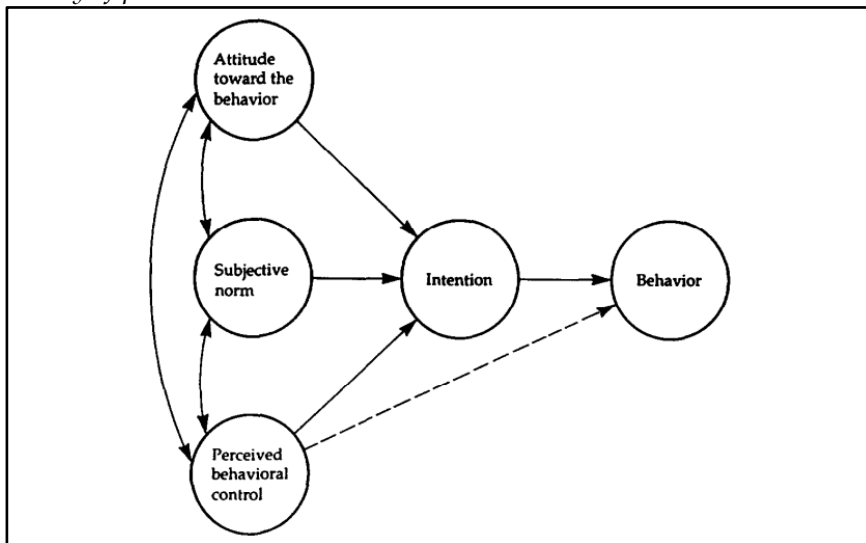

Note. Adapted from Ajzen (1991).

Figure 2
Research framework

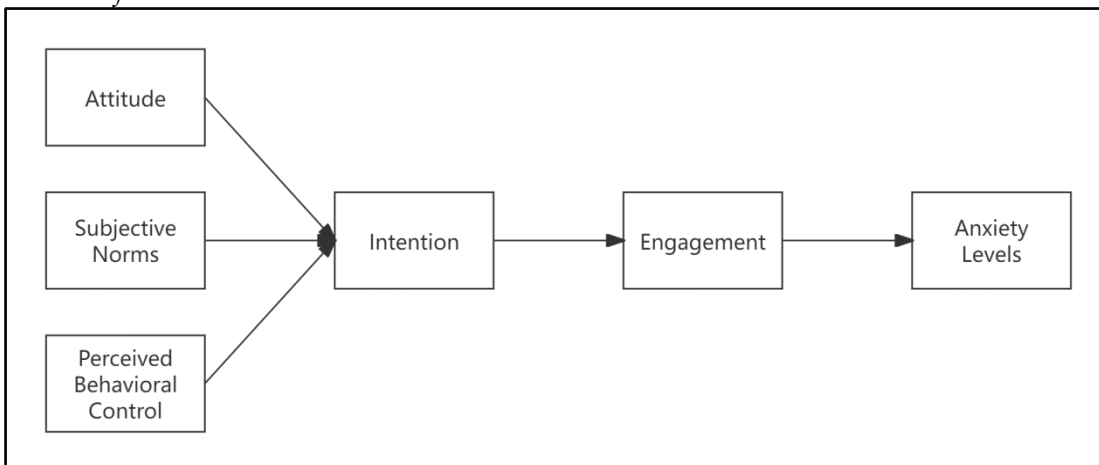

Based on this framework, we propose the following hypotheses:

H1: A more positive attitude toward music therapy will lead to a greater intention to engage in music therapy.

H2: Stronger subjective norms in favor of music therapy will lead to greater intentions to engage in music therapy.

H3: Increased perceived behavioral control over engaging in music therapy will lead to increased intention to engage in music therapy.

H4: A greater intention to engage in music therapy will result in more substantial engagement in music therapy sessions.

H5: Increased engagement in music therapy sessions will be associated with lower anxiety levels.

3. Methodology

3.1. Research Design and Participants

This was a quantitative study in which the main research instrument was a questionnaire survey, and it focused on university students in Guangdong Province. A sample size of more than 350 participants was chosen because Kline (2011) and Bentler and Chou (1987) suggested using larger

sample sizes when complex analyses and multiple variables are available to ensure stable parameter estimates.

Specifically, we targeted university students from Guangdong Province. These people were chosen due to their accessibility and high likelihood of experiencing anxiety-related problems. Participants were from various universities across the province, ensuring the participation of a wide range of academic disciplines. The inclusion criteria for participants included being currently enrolled as university students in Guangdong Province, aged 18 years or older, and self-reported experiences of mild to moderate anxiety. People who had undergone intensive psychiatric treatments or had severe psychiatric conditions were excluded because we could have a relatively homogeneous group with only typical pressure associated with university life.

The sampling method used was stratified random sampling so that all university populations were represented in equal ratios. In this way, none would be underrepresented, as it would skew the results by selecting too many participants from one specific school instead of spreading them out evenly between all schools within the province, across genders, or across academic years. As shown in Table 1, the participant pool comprised 70 Freshmen with a slightly male-dominant distribution (52.9% male, 47.1% female), 75 Graduate students with a female majority (54.7%), 71 Juniors with an almost equal sex split, 56 Seniors evenly divided by sex, and 78 Sophomores with a female majority (53.8%). Regarding previous exposure to music therapy, out of 350 participants, 189 had no prior experience, showing an almost balanced sex distribution, while 161 had some experience, with a slight female predominance.

Table 2
Demographic characteristics of the participants

Categories	Gender		Total
	Male	Female	
Education level			
Freshman	33(47.1%)	37(52.9%)	70
Graduate student	41(54.7%)	34(45.3%)	75
Junior	35(49.3%)	36(50.7%)	71
Senior	28(50.0%)	28(50.0%)	56
Sophomore	42(53.8%)	36(46.2%)	78
Previous participation			
No	94(49.7%)	95(50.3%)	189
Yes	85(52.8%)	76(47.2%)	161

3.2. Data Collection

To assess the progress of our investigation into the therapeutic advantages of music therapy, we utilized the Wenjuanxing platform (www.wjx.cn). Due to its ability to reach a wide range of participants, this online survey tool is widely utilized by several individuals. Our study focused mainly on university students in China, and we required a method that would effectively reach all of them. Our questionnaire was accessible from January 10, 2023, to January 25, 2023. The study assessed participants' attitudes, subjective norms, perceived behavioural control, and intentions towards involvement in music therapy, as well as their actual degrees of engagement. The survey was implemented in alignment with the elements of the Theory of Planned Behaviour to effectively gather essential data for the study's aims.

3.3. Measurement of Variables

We utilized a variety of meticulously chosen items to assess the crucial variables obtained from our hypotheses. Every variable is evaluated using items that have been modified from well-established scales in the existing body of research, guaranteeing both pertinence and dependability. The items are organized in a manner that corresponds to a 5-point Likert scale, which enables participants to articulate their degree of concurrence or discord (see Table 2).

Table 2
Variable items

Variable Name	Items in the Literature	Items in Our Study	Source
Attitude Towards Music Therapy	Attitudes and beliefs about music therapy effectiveness.	ATT 1.I believe music therapy is effective in reducing psychological stress. ATT 2.Music therapy is a valuable tool for mental health. ATT 3.Music therapy can positively impact overall emotional well-being.	Mah et al. (2019)
Subjective Norms in Favor of Music Therapy	Perception of social support or pressure regarding music therapy.	AN 1.My family and friends support the use of music therapy for health. AN 2.In my social circle, music therapy is seen as beneficial. AN 3.People whose opinions I value perceive music therapy as an effective treatment method.	Huang and Yang (2018)
Perceived Behavioral Control	Belief in capability and resources to engage in music therapy.	BC 1.I am confident in my ability to regularly attend music therapy sessions. BC 2.I feel in control of participating in music therapy. BC 3.I have the necessary resources (time, money, access) to engage in music therapy.	Barbera and Ajzen (2020)
Intention to Engage in Music Therapy	Intention to participate in music therapy and motivation for engagement.	INT 1.I am willing to attend future music therapy sessions. INT 2.I am motivated to engage in music therapy for my well-being. INT 3.I plan to actively seek out music therapy opportunities.	Yoo (2020)
Engagement in Music Therapy Sessions	Active participation and involvement in music therapy activities.	ENG 1.I actively participate during music therapy sessions. ENG 2.I involve myself in the activities during music therapy sessions. ENG 3.I find myself fully immersed in the music therapy experience.	Tan et al. (2018)
Anxiety Levels	State and Trait Anxiety Inventory [STAI] for measuring anxiety levels.	AL 1.I feel anxious before music therapy sessions. AL 2.My level of anxiety decreases after participating in music therapy sessions. AL 3.I feel more relaxed and less stressed after a music therapy session.	Chen et al. (2016)

3.4. Data Analysis

In our study investigating the impact of music therapy on anxiety levels, we employed SPSS to conduct initial statistical analyses. Reliability and validity assessments were also conducted on the questionnaire responses. Reliability was evaluated using Cronbach's alpha to ensure that the scales were internally consistent while evaluating dimensions such as attitudes, subjective norms, perceived behavioural control, and anxiety levels. Regarding validity, our primary focus was on assessing the adequacy of the sample by utilizing tools such as the Kaiser-Meyer-Olkin [KMO] test. This approach allowed us to ensure that all the questionnaire items effectively represented the intended theoretical structures.

After performing the initial analysis, we proceeded to utilize structural equation modelling [SEM] to investigate the specific interactions between these structures, as outlined in our research model. Structural equation modelling enabled us to comprehensively examine the impact of attitudes, subjective norms, and perceived behavioral control on an individual's intention to participate in music therapy, as well as its subsequent effect on anxiety levels.

4. Results

4.1. Reliability and Validity

Table 3 presents a Cronbach's alpha coefficient of 0.866, with a standardized alpha of 0.822, for the 18-item questionnaire administered to a sample of 350 participants, indicating a high degree of internal consistency and reliability. These values exceed the commonly accepted threshold of 0.7, indicating that the questionnaire items cohesively measure the underlying constructs.

Table 3

Cronbach's a coefficient

<i>Cronbach's a coefficient</i>	<i>Standardized Cronbach's a coefficient</i>	<i>Items No.</i>	<i>Samples No.</i>
0.866	0.822	18	350

Based on the item statistics for the questionnaire, it can be seen that deletion of specific items results in varying effects on the overall Cronbach's alpha coefficient, as shown in Table 4.

Table 4

Statistics of the analyses after deletion of items

	<i>Average value</i>	<i>Variance</i>	<i>Correlation</i>	<i>Cronbach's a coefficient</i>
ATT1	48.471	112.003	.649	.851
ATT2	48.72	117.537	.569	.855
ATT3	48.706	118.14	.544	.856
AN1	48.56	111.749	.673	.85
AN2	48.777	120.036	.502	.858
AN3	48.78	118.625	.531	.857
BC1	48.329	110.571	.683	.849
BC2	48.691	117.664	.555	.856
BC3	48.651	116.709	.582	.854
INT1	48.423	111.546	.66	.85
INT2	48.677	117.016	.566	.855
INT3	48.666	116.836	.596	.854
ENG1	48.423	111.58	.677	.849
ENG2	48.763	117.941	.559	.856
ENG3	48.637	117.401	.573	.855
AL1	50.026	139.372	-.409	.881
AL2	49.969	138.747	-.379	.881
AL3	49.971	138.486	-.358	.88

For most items, especially under categories such as Attitude [ATT], Anxiety [AN], Perceived Behavioral Control [BC], Intention [INT], and Engagement [ENG], deletion leads to alpha coefficients ranging from 0.849 to 0.858, suggesting slight fluctuations but overall maintenance of a high level of internal consistency. Notably, items related to anxiety levels (AL1, AL2, AL3) exhibited a unique pattern, where their removal led to an increase in the alpha coefficient (.880 to .881), indicating a possible divergence in how these items align with the rest of the scale.

The KMO's test yielded a value of 0.896, indicating a high level of sampling adequacy and suitability for factor analysis, as values above 0.8 is generally considered good, suggesting that the patterns of correlations among questionnaire items are compact. Furthermore, Bartlett's test of sphericity showed an approximate chi-square value of 3167.805 with 153 degrees of freedom and a highly significant p -value of less than .001. This significant result implies a rejection of the null hypothesis that the correlation matrix is an identity matrix, confirming that the variables are interrelated and thus apt for factor analysis.

4.2. Structural Equation Modelling Test

The SEM analysis conducted in our study provides empirical support for the theoretical constructs proposed in the TPB, specifically in the context of music therapy as an intervention for anxiety reduction.

As shown in Table 5, the SEM results indicate a significant positive relationship between 'Attitude' and 'Intention to Engage in Music Therapy', as evidenced by a unstandardized coefficient of 0.302 and a standardized coefficient of 0.319 ($Z = 5.143$, $p < .001$). This finding suggested that favorable attitudes toward music therapy significantly enhance the intention to engage in such therapy. Similarly, 'Subjective Norms' are positively associated with 'Intention to Engage in Music Therapy' (unstandardized coefficient = 0.266, standardized coefficient = 0.28, $Z = 4.519$, $p < .001$), underscoring the influence of perceived social support and pressure on shaping individuals' intentions.

Table 5

Model regression coefficient

$X \rightarrow Y$	Unstandardized coefficients	Standardized coefficient	SE	Z	p
Attitude \rightarrow Intention	0.302	0.319	0.059	5.143	.000
Subjective Norms \rightarrow Intention	0.266	0.28	0.059	4.519	.000
PBC \rightarrow Intention	0.257	0.28	0.059	4.383	.000
Intention \rightarrow Engagement	0.693	0.692	0.056	12.288	.000
Engagement \rightarrow Anxiety Levels	-0.236	-0.648	0.031	-7.654	.000

Moreover, the analysis revealed that "perceived behavioural control" [PBC] positively influences "intention to engage in music therapy" (unstandardized coefficient = 0.257, standardized coefficient = 0.28, $Z = 4.383$, $p < .001$), indicating that ease of access and the perceived ability to participate effectively in music therapy are critical in fostering the intention to engage. A particularly strong relationship was observed between 'Intention to Engage in Music Therapy' and 'Engagement in Music Therapy Sessions' (unstandardized coefficient = 0.693, standardized coefficient = 0.692, $Z = 12.288$, $p < .001$), affirming that the intention to engage is a powerful predictor of actual engagement in therapy sessions.

Furthermore, the analysis demonstrated a significant negative relationship between 'Engagement in Music Therapy Sessions' and 'Anxiety Levels' (unstandardized coefficient = -0.236, standardized coefficient = -0.648, $Z = -7.654$, $p < .001$). This finding is pivotal because it indicates that increased engagement in music therapy sessions is associated with a notable decrease in anxiety levels among participants, thus validating the effectiveness of music therapy as a therapeutic intervention for anxiety.

To visually represent the relationships and pathways identified in our study on the efficacy of

music therapy in reducing anxiety among university students, we constructed an SEM path diagram, as shown in Figure 3.

Figure 3
Path diagram of the structural equation model

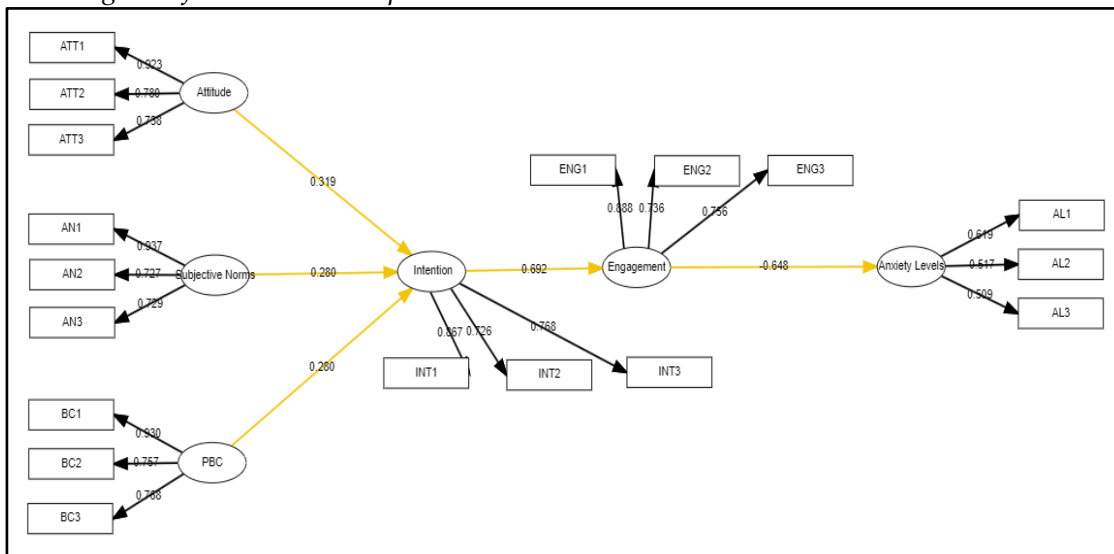

Moreover, the results of the SEM analysis of the effectiveness of music therapy for reducing anxiety in our study demonstrated several key indicators that affirm the adequacy of the model. The chi-square value of 236.636 with 127 degrees of freedom, while significant ($p < .001$), yields a chi-square-to-degrees of freedom ratio of 1.863. This value falls well below the recommended threshold of 3, suggesting a satisfactory fit between the model and the observed data. The goodness-of-fit index [GFI] is 0.927, surpassing the standard criterion of 0.9 and indicating a good fit of the model to the data. Moreover, the root mean square error of approximation [RMSEA] is 0.05, within the acceptable limit of less than 0.10, denoting a close approximation of the model with the observed data. Although the root mean square residual [RMR] is 0.705, which is slightly above the preferred threshold, it does not significantly detract from the overall model fit. The comparative fit index [CFI], normed fit index [NFI], and nonnormed fit index [NNFI] all exceeded the 0.9 benchmark (CFI = 0.964, NFI = 0.927, NNFI = 0.957), further corroborating the model's robustness.

5. Discussion

Study conducted in Guangdong Province has demonstrated that music therapy has the ability to diminish stress levels among university students. The study utilises the theory of planned behaviour to elucidate the factors that drive individuals to pursue a specific objective. The results of this study align with other research, since we observed a decrease in mental stress through the use of music therapy (Dash, 2017). However, on this occasion, we examined higher education students who experience distinct sources of pressure compared to others. The findings revealed that individuals who participated in musical therapy had reduced levels of anxiety in comparison to those who did not engage in the therapy (Dash, 2017). This suggests that it can be utilised as a technique for managing academic stress, among other potential uses. The role of TPB in health-related behaviours was corroborated by other research conducted by Murrock and Bekhet (2016) and Legge (2015).

The analysis established a robust correlation between the strategies employed and their reliability. We achieved this by obtaining high alpha values for Cronbach's alpha and good fit indices from SEM analysis. These two measures are commonly used to assess the reliability of studies similar to ours (Bentler & Chou, 1987; Kline, 2011). In addition, we utilised data collected from diverse educational levels regarding previous encounters with music therapy to bolster

credibility, particularly when making broad statements.

These findings corroborate the increasing body of research that highlights the efficacy of music therapy in lowering anxiety and boosting mental well-being. According to a comprehensive study conducted by Witte et al. (2020), it was discovered that music intervention had significant impact on reducing physiological and psychological stress-related outcomes, with effect sizes ranging from medium to large. Hence, our conclusion remains unchanged that it is a potent therapy for controlling anxiety disorders among university students. Facchini and Ruini (2020) demonstrated the viability of music therapy and its positive impact on the mental well-being of children and adolescents with cancer. This supports the notion that music therapy is applicable to various age groups and health conditions.

The involvement of the TPB in predicting health-related behaviours, as demonstrated by our research, is further substantiated by the concept analysis conducted by Murrock and Bekhet (2016). This analysis highlights the therapeutic features that contribute to its effectiveness, thereby providing theoretical support for our findings. Legge (2015) provided an explanation from a neurobiological standpoint on how music therapy helps to control emotions. This is particularly beneficial in mental health settings, such as colleges.

Examining university students is particularly relevant due to their susceptibility to experiencing anxiety. Luo et al. (2020) asserted that medical professionals have faced significant psychological consequences as a result of the COVID-19 pandemic, and the general public has also reported increased levels of depression and anxiety disorders. Consequently, under challenging circumstances such as these, when individuals are facing numerous difficulties, music therapy can be a valuable approach for effectively coping with anxiety among college students.

If we desire to enhance mental health services for students in higher education, it is imperative that we give due consideration to these findings. This study discovered two key findings: music therapy enjoys widespread popularity and has proven to be highly beneficial. This data can serve as an alternate or supplementary therapy method to normal psychological processes. Integrating music therapy into mental health services at universities has the potential to not only decrease student anxiety but also function as a cost-efficient and captivating alternative to conventional therapeutic approaches (Nicolescu et al., 2024).

Nevertheless, our findings are constrained by some characteristics such as geographical or demographic specificity, rendering them inapplicable beyond those particular regions or people. To gain a deeper understanding of how music impacts emotional well-being on a broader scale, it is necessary to conduct additional investigations in various situations or over extended periods of time. Furthermore, it would be beneficial to explore the specific methods by which community building, as described by Landis-Shack et al. (2017), contributes to anxiety reduction through emotion regulation in therapy sessions that focus on these particular concerns, using music as a tool.

6. Conclusion

Our study, which examined the effects of music therapy on reducing anxiety among university students in Guangdong Province, confirmed several key hypotheses rooted in the theory of planned behaviour.

The data strongly support Hypothesis 1, showing that a more positive attitude toward music therapy significantly increases the intention to engage in such therapy. This finding is consistent with the literature and highlights the critical role of individuals' beliefs and perceptions about the effectiveness of music therapy in shaping their willingness to participate. Hypothesis 2 was also supported, as stronger subjective norms in favour of music therapy were found to increase the intention to participate. This underscores the influence of social factors, including perceived support and pressure from significant others, in guiding decisions about therapy engagement. In addition, Hypothesis 3 was empirically supported by our analysis, which highlights that greater perceived behavioural control, which includes factors such as accessibility and self-efficacy,

positively influences the intention to engage in music therapy. This finding is consistent with the broader understanding in health psychology that perceived control is a critical determinant of health-related behaviour. Hypothesis 4 was confirmed, revealing a direct and significant relationship between the intention to engage in music therapy and actual engagement in therapy sessions. This finding strengthens the argument that intention, as a cognitive precursor, is a strong predictor of behaviour. Finally, Hypothesis 5 was validated, demonstrating that increased engagement in music therapy sessions is associated with lower anxiety levels, thereby reinforcing the efficacy of music therapy as a viable intervention for anxiety management.

In conclusion, this study not only provides empirical evidence for the effectiveness of music therapy in reducing anxiety in university students but also highlights the importance of cognitive factors in the acceptance of therapeutic interventions.

Author contributions: Meng Zhang contributed to the conceptualization, methodology design, data collection, initial manuscript drafting, and revision processes. Yoon Fah Lay played a key role in manuscript revision, ensuring clarity and accuracy in the presentation of findings.

Availability of data and materials: The datasets used and/or analysed during the current study available from the corresponding author on reasonable request.

Declaration of interest: The authors declare that there are no conflicts of interest regarding the publication of this paper.

Ethics declaration: The authors declare that this study was conducted in accordance with the ethical standards of the UCSI University, Malaysia.

Funding: No funding was obtained for this study.

References

- Ajzen, I. (1991). The theory of planned behavior. *Organizational behavior and human decision processes*, 50(2), 179-211. [https://doi.org/10.1016/0749-5978\(91\)90020-T](https://doi.org/10.1016/0749-5978(91)90020-T)
- Alzahrani, M., Alfahaid, F., Almansour, M., Alghamdi, T., Ansari, T., Sami, W., Otaibi, T., Humayn, A., & Enezi, M. (2017). Prevalence of generalized anxiety disorder and major depression in health-care givers of disabled patients in Majmaah and Shaqra cities, Kingdom of Saudi Arabia. *International Journal of Health Sciences*, 11, 9 - 13.
- Bae, S. Y., & Chang, P. J. (2021). The effect of coronavirus disease-19 (COVID-19) risk perception on behavioural intention towards 'untact' tourism in South Korea during the first wave of the pandemic (March 2020). *Current Issues in Tourism*, 24(7), 1017-1035. <https://doi.org/10.1080/13683500.2020.1798895>
- Barbera, F., & Ajzen, I. (2020). Control interactions in the theory of planned behavior: rethinking the role of subjective norm. *Europe's Journal of Psychology*, 16, 401 - 417. <https://doi.org/10.5964/ejop.v16i3.2056>
- Bentler, P. M., & Chou, C. P. (1987). Practical issues in structural modeling. *Sociological Methods & Research*, 16(1), 78-117. <https://doi.org/10.1177/0049124187016001004>
- Chen, X., Hannibal, N., & Gold, C. (2016). Randomized trial of group music therapy with chinese prisoners. *International Journal of Offender Therapy and Comparative Criminology*, 60, 1064 - 1081. <https://doi.org/10.1177/0306624X15572795>
- Dash, D. (2017). Music therapy on cancer patient: a case study. *International Journal of Indian Psychology*, 4(3), 160. <https://doi.org/10.25215/0403.160>
- Facchini, M., & Ruini, C. (2020). The role of music therapy in the treatment of children with cancer: A systematic review of literature. *Complementary Therapies in Clinical Practice*, 42, 101289. <https://doi.org/10.1016/j.ctcp.2020.101289>
- Gerstgrasser, S., Vigl, J., & Zentner, M. (2023). The role of listener features in musical emotion induction: The contributions of musical expertise, personality dispositions, and mood state. *Psychology of Aesthetics, Creativity, and the Arts*, 17(2), 211. <https://doi.org/10.1037/aca0000468>
- Geyik, G., Doğan, S., Ozbek, H., & Atayoğlu, A. (2020). The effect of music therapy on the physical and mental parameters of cancer patients during hematopoietic stem cell transplantation. *Perspectives in Psychiatric Care*, 57(2), 558-564. <https://doi.org/10.1111/ppc.12578>
- Gottschalk, M. G., & Domschke, K. (2017). Genetics of generalized anxiety disorder and related traits.

- Dialogues in Clinical Neuroscience*, 19(2), 159-168. <https://doi.org/10.31887/DCNS.2017.19.2/kdomschke>
- Gutiérrez, E. O. F., & Camarena, V. A. T. (2015). Music therapy in generalized anxiety disorder. *The Arts in Psychotherapy*, 44, 19-24. <https://doi.org/10.1016/j.aip.2015.02.003>
- Huang, K., & Yang, Y. (2018). Explore the intention of clients in long-term-care facilities to accept occupational therapy services. *Journal of Business & Economic Policy*, 5(2), 51-58. <https://doi.org/10.30845/JBEP.V5N2A8>
- Hufnagel, C., Chambres, P., Bertrand, P., & Dutheil, F. (2017). The need for objective measures of stress in autism. *Frontiers in Psychology*, 8, 64. <https://doi.org/10.3389/fpsyg.2017.00064>
- Irgebaeva, N., & Akmusaeva, M. (2020). Anxiety of the person emotional status. *Bulletin Series Psychology*, 64, 23-30. <https://doi.org/10.51889/2020-3.1728-7847.04>
- Karki, M., & Mahara, G. (2022). Heart diseases, anxiety disorders, and negative thoughts. *Heart and Mind*, 6(1), 22-25. https://doi.org/10.4103/hm.hm_45_21
- Kenny, D., & Halls, N. (2018). Development and evaluation of two brief group interventions for music performance anxiety in community musicians. *Psychology of Music*, 46, 66 - 83. <https://doi.org/10.1177/0305735617702536>
- Kline, R. B. (2023). Principles and practice of structural equation modelling. Guilford publications.
- Landis-Shack, N., Heinz, A., & Bonn-Miller, M. (2017). Music therapy for posttraumatic stress in adults: a theoretical review. *Psychomusicology: Music, Mind, and Brain*, 27, 334-342. <https://doi.org/10.1037/pmu0000192>
- Legge, A. (2015). On the neural mechanisms of music therapy in mental health care: literature review and clinical implications. *Music Therapy Perspectives*, 33, 128-141. <https://doi.org/10.1093/MTP/MIV025>
- Lok, J. G. (2013). *Nurses' awareness of and intention to use music therapy in practice* [Unpublished doctoral dissertation]. University of Toronto, Toronto.
- Lu, G., Jia, R., Liang, D., Yu, J., Wu, Z., & Chen, C. (2021). Effects of music therapy on anxiety: A meta-analysis of randomized controlled trials. *Psychiatry Research*, 304, 114137. <https://doi.org/10.1016/j.psychres.2021.114137>
- Lund, H., Bertelsen, L., & Bonde, L. (2016). Sound and music interventions in psychiatry at Aalborg University Hospital. *SoundEffects - An Interdisciplinary Journal of Sound and Sound Experience*, 6, 48-68. <https://doi.org/10.7146/SE.V6I1.24912>
- Luo, M., Guo, L., Yu, M., Jiang, W., & Wang, H. (2020). The psychological and mental impact of coronavirus disease 2019 (COVID-19) on medical staff and general public – A systematic review and meta-analysis. *Psychiatry Research*, 291, 113190. <https://doi.org/10.1016/j.psychres.2020.113190>
- Mah, A., Hill, K., Cicero, D., & Nakamura, B. (2019). A psychometric evaluation of the intention scale for providers-direct items. *The Journal of Behavioral Health Services & Research*, 47, 245-263. <https://doi.org/10.1007/s11414-019-09675-3>
- Mastnak, W. (2023). Music therapy: scientific perspectives and clinical prospects. *Proceedings of the European Academy of Sciences & Arts*, 1(2), 1-20.
- McEvoy, P., Hyett, M., Shihata, S., Price, J., & Strachan, L. (2019). The impact of methodological and measurement factors on transdiagnostic associations with intolerance of uncertainty: A meta-analysis. *Clinical psychology review*, 73, 101778. <https://doi.org/10.1016/j.cpr.2019.101778>
- Murrock, C., & Bekhet, A. (2016). Concept analysis: music therapy. *Research and Theory for Nursing Practice*, 30, 44 - 59. <https://doi.org/10.1891/1541-6577.30.1.44>
- Nayanajith, D. G., & Damunupola, K. A. (2020). Impact of perceived behavioral control on e-learning adoption. *Interdisciplinary Research in Education*, 5(1-2), 1-14.
- Nicolescu, A. C., Strilciuc, S., Lapadatu, R., Grad, D. A., Vladescu, C., & Olteanu, R. (2024). The economic burden of atopic dermatitis in Romania: a broad perspective. *Preprints*, 2024, 2024010830. <https://doi.org/10.20944/preprints202401.0830.v2>
- Niknamian, S. (2019). The impact of stress, anxiety, fear and depression in the cause of cancer in humans. *American Journal of Biomedical Science & Research*, 3(4), 696. <https://doi.org/10.34297/AJBSR.2019.03.000696>
- Salur, Ö., Ala-Ruona, E., Ucar, S., & Eren, N. (2017). Enjoying expression: Exploring the benefits of music therapy on patients diagnosed with schizophrenia and using metaphor games/improvisations for increasing emotional awareness level. *European Psychiatry*, 41, 835-835. <https://doi.org/10.1016/j.eurpsy.2017.01.1642>
- Starcke, K., Mayr, J., & von Georgi, R. (2021). Emotion modulation through music after sadness induction – The iso principle in a controlled experimental study. *International journal of environmental research and*

- public health*, 18(23), 12486. <https://doi.org/10.3390/ijerph182312486>
- Tan, J., Wee, S., Yeo, P., Choo, J., Ritholz, M., & Yap, P. (2018). A new music therapy engagement scale for persons with dementia. *International Psychogeriatrics*, 31, 49-58. <https://doi.org/10.1017/S1041610218000509>
- Tsiris, G. (2017). Music therapy and spirituality: An international survey of music therapists' perceptions. *Nordic Journal of Music Therapy*, 26(4), 293-319.
- Witte, M., Orkibi, H., Zárate, R., Karkou, V., Sajnani, N., Malhotra, B., Ho, R., Kaimal, G., Baker, F., & Koch, S. (2021). From therapeutic factors to mechanisms of change in the creative arts therapies: a scoping review. *Frontiers in Psychology*, 12, 678397 <https://doi.org/10.3389/fpsyg.2021.678397>
- Witte, m., Pinho, A., Stams, G., Moonen, X., Bos, A., & Hooren, S. (2020). Music therapy for stress reduction: a systematic review and meta-analysis. *Health Psychology Review*, 16, 134 - 159. <https://doi.org/10.1080/17437199.2020.1846580>
- Wong, M., Tahir, T., Wong, M., Baron, A., & Finnerty, R. (2021). Biomarkers of stress in music interventions: a systematic review. *Journal of Music Therapy*, 58(3), 241-277. <https://doi.org/10.1093/jmt/thab003>
- Yoo, H. (2020). Factors influencing future music participation: a review of literature based on the theory of planned behavior. *Update: Applications of Research in Music Education*, 38, 18-28. <https://doi.org/10.1177/8755123320904748>
- Zang, L., Cheng, C., Zhou, Y., & Liu, X. (2023). Music therapy effect on anxiety reduction among patients with cancer: A meta-analysis. *Frontiers in Psychology*, 13, 1028934. <https://doi.org/10.3389/fpsyg.2022.1028934>