

Research Article

Interaction between pre-service chemistry teachers' pedagogical content knowledge and content knowledge in electrochemistry

Elif Selcan Oztay¹ and Yezdan Boz²

¹Department of Elementary Education, Van Yuzuncu Yil University, Turkey (ORCID: 0000-0001-6156-1950)

²Department of Mathematics and Science Education, Middle East Technical University, Turkey (ORCID: 0000-0002-3122-9671)

The purpose of this study was to delve into the interaction between pre-service chemistry teachers' pedagogical content knowledge (PCK) and content knowledge (CK) while teaching electrochemistry. Two pre-service chemistry teachers enrolled in practice teaching course in chemistry education program participated in the study. All PCK components were included in the current study. Qualitative methodology was used and the participants were selected through purposeful sampling. Data were collected through electrochemistry content test, Content Representation (CoRe), semi-structured interviews, video stimulated recall interviews, classroom observations and field notes. Results indicated that the level of CK impacted PCK: basic level of CK is a prerequisite for developing PCK, while a high CK does not guarantee a high PCK to the same extent. Pre-service teachers with weak content knowledge had problems in recognizing students' possible misconceptions, using vertical and horizontal relations in the curriculum and using the topic-specific instructional strategies effectively. The level of content knowledge did not have a strong impact on choice of subject-specific instructional strategies, assessing students' understanding, and science teaching orientations of pre-service teachers. This study highlights that the quality of PCK depends on the interaction between content knowledge and the components of PCK. From a methodological perspective, this study demonstrates the possibility of making pre-service teachers' PCK more accessible by utilizing video stimulated recall interviews. Implications for pre-service teacher education aim to support pre-service teachers to establish a bridge between their content knowledge and teaching knowledge through teacher education program.

Keywords: Pedagogical content knowledge; Content knowledge; Pre-service teachers; Electrochemistry, Qualitative research

Article History: Submitted 16 December 2021; Revised 17 March 2022; Published online 23 March 2022

1. Introduction

In recent years, there has been an increasing interest in developing a knowledge base for teaching science (Aydin-Günbatar & Akin, 2022). In this issue, teachers have an essential role, so both teachers and pre-service teachers need to develop their skills and knowledge in many domains such as content knowledge (CK), general pedagogical knowledge and pedagogical content knowledge (PCK) to have an effective role in classrooms and schools (Boz & Boz, 2008;

Address of Corresponding Author

Elif Selcan Oztay, PhD, Van Yuzuncu Yil University, College of Education, Department of Elementary Education, 65090, Van, Turkey.

✉ selcan.kutucu@gmail.com

How to cite: Oztay, E. S., Boz, Y. (2022). Interaction between pre-service chemistry teachers' pedagogical content knowledge and content knowledge in electrochemistry. *Journal of Pedagogical Research*, 6(1), 245-269. <https://dx.doi.org/10.33902/JPR.2022.165>

Goodnough & Hung, 2009; Van Driel et al., 2002). In order to improve the qualifications of teachers, before all else, as educators, we ought to discover general and specific qualifications that teachers should have and help pre-service teachers gain these qualifications in teacher education programs. In this respect, pre-service teachers need to develop a special form of knowledge, PCK, through a teacher education program (Sæleset & Friedrichsen, 2021). From this point, pre-service teachers should gain these abilities and knowledge in teacher education programs; hence pre-service teachers' PCK can affect the quality of their teaching and their future students' achievement (Gess-Newsome, 1999).

Shulman (1987) introduced PCK as "...that special amalgam of content and pedagogy that is uniquely the province of teachers, their own special form of professional understanding" (p.8). In other words, CK and pedagogical knowledge in terms of instructional practices, educational objectives, knowledge of learners, knowledge of assessment techniques, classroom management were accumulated in one construct namely PCK (Magnusson et al., 1999; Sande, 2010). Some other scholars extended Shulman (1986, 1987)'s model by adding some of the categories of knowledge over time (Carlson & Daehler, 2019; Gess-Newsome, 2015; Hashweh, 2005; Magnusson et al., 1999; Tamir, 1988). Although there are differences among PCK models in terms of PCK components, there is a consensus that CK, pedagogical knowledge and context knowledge domains contribute to the formation of PCK. In order to teach effectively, in-service and pre-service teachers transform and interact with these knowledge domains. Moreover, Mavhunga (2016) emphasized that "learning to transform content knowledge is a central element of the teaching of PCK to pre-service teachers" (p. 1081). Teachers are supposed to gain more in-depth knowledge of the discipline they are teaching (Şen et al., 2022). The relation between CK and PCK has been often debated in the literature (Childs & McNicholl, 2007; Kind, 2009b) but there is no consensus about how they are related and this needs further research (Şen et al., 2018).

In terms of the topic that was focused in this study, electrochemistry has been accepted as one of the most difficult chemistry topics for students to learn and for teachers to teach (De Jong & Treagust, 2002), and both teachers and students had a wide a range of misconceptions in electrochemistry (Acar & Tarhan, 2007; Garnett & Treagust, 1992; Ogude & Bradley, 1994; Sanger & Greenbowe, 1997a; 1997b). Moreover, electrochemistry is a crucial topic in chemistry because it has wide range of daily life applications such as batteries, electroplating, corrosion and so forth. Furthermore, the place of electrochemistry in the curriculum is also important: electrochemistry has links to chemical equilibrium, types of reactions and thermodynamics (Rollnick & Mavhunga, 2014). Furthermore, in teaching electrochemistry, there have not been so many studies (Aydin et al. 2014; Rollnick & Mavhunga, 2014) and De Jong and Treagust (2002) called for the research pertained to teaching of electrochemistry. The purpose of this study is to examine how pre-service chemistry teachers' CK and PCK interact while teaching electrochemistry.

2. Theoretical Framework

Shulman (1987) described "the knowledge base for teaching" as the knowledge that teachers should possess, including PCK. This knowledge base includes seven categories, namely CK, PCK, curriculum knowledge, learners and their characteristics, educational contexts, and educational purposes. In this second article, Shulman described PCK as a category on its own not as a subcategory as described in the article in 1986. Some other scholars extended Shulman's model by adding some of the categories of knowledge over time (Carlson & Daehler, 2019; Gess-Newsome, 2015; Grossman, 1990; Hashweh, 2005; Magnusson et al., 1999). This study relied on one of the most widely used Magnusson et al.'s (1999) PCK model to examine pre-service teachers' PCK. Magnusson et al. (1999) described the PCK transformation process "of several types of knowledge for teaching" (p. 95). According to Magnusson et al. (1999), PCK was composed of five components: (a) orientation toward science teaching (STO), (b) knowledge of students' understanding (KoL), (c) knowledge of instructional strategies (KoIS), (d) knowledge of science curriculum (KoC), and knowledge of science assessment (KoAs). Orientation to science teaching

(STO), accepted as an overarching component of PCK, refers to teachers' knowledge and beliefs about purposes and goals for science teaching. Knowledge of learner (KoL) pertains to knowledge that teachers are supposed to know about students. KoL is composed of prerequisite knowledge for learning the specific science topic and knowledge on difficulties and misconceptions students may have related to the science topic. Knowledge of instructional strategy (KoIS) consisted of subject-specific and topic-specific strategies. While subject-specific strategies are appropriate and implementable to science subjects (e.g., Learning cycle, guided inquiry), topic-specific strategies include representations and activities to teach a specific topic (e.g., animations, demonstration). Knowledge of science Curriculum (KoC) is another component, including the knowledge of goals and objectives, knowledge of materials and programs, and knowledge of both vertical and horizontal relation of curriculum for a subject. Knowledge of assessment (KoAs) is comprised of the knowledge of the dimension of science learning that is important to assess and knowledge of the methods used while assessing that learning (Magnusson et al. 1999). CK was defined by several researchers (Jüttner et al., 2013; McConnell et al., 2013; Tamir, 1988; Shulman, 1986) in different perspectives. CK, often called subject matter knowledge (SMK), is considered a crucial precondition for effective teaching (Shulman, 1986; Jüttner et al. 2013). According to Jüttner et al., (2013) CK includes declarative knowledge meaning "knowing that", procedural knowledge meaning "knowing how" and conditional knowledge meaning "knowing how and why". Moreover, Shulman (1986) emphasized the need to understand CK during instruction as "[t]he teacher need not only understand that something is so, the teacher must further understand why it is so" (p. 9). Taking the definitions of CK into account, in this study, CK refers to knowledge about fundamental concepts, facts, and principles of the subject, knowledge regarding the connection of chemistry with other disciplines and real-life applications of chemistry, and knowledge regarding chemistry concepts and principles.

3. Literature Review

CK and PCK are viewed as crucial knowledge domains of teachers' professional knowledge in the related literature (Abell, 2007; Jüttner et al., 2013). PCK is thought to be a special body of knowledge, a blend of CK and pedagogy that teachers should have for effective teaching (Shulman, 1987). Many knowledge domains have contributed to effective teaching, but researchers have drawn attention to CK (Kind, 2009b; Magnusson et al., 1999). Research studies have emphasized that having deep understanding of science CK plays an important role in improving and changing teachers' instructional practices (Halim & Meerah, 2002; Hashweh, 1987; Van Driel et al., 1998, 2002). On the other hand, researchers have also emphasized that having good CK is not sufficient for effective teaching (Abell, 2007; Fischer et al., 2012; Kind, 2009a), and Mapolelo (1999) stated that strong CK does not lead to improvement of PCK. Thus, researchers have some controversy about the role of CK in teaching performance. Therefore, researches indicated that both having CK and PCK play a crucial role in teaching but the relation between these two constructs unclear.

In the current literature, there have been studies that investigate the relation between CK and PCK (Childs & McNicholl, 2007; Kaya, 2009; Kaya et al. 2021; Käpylä et al. 2009; Kind, 2009a; Rollnick et al. 2008; Sanders et al., 1993; Şen et al., 2018), the outcomes of these studies are contradictory. For instance, Kaya (2009) conducted a quantitative research with 216 pre-service teachers and found that participants with good CK tended to have rich PCK. Similarly, Rollnick et al. (2008) examined the role of SMK on PCK of two in-service South Africa teachers while teaching the mole and chemical equilibrium topics. The findings of the study indicated that the lack of SMK on the topics constrained teachers' teaching and limited their flexibility in their teaching. However, having powerful PCK led teachers to explain the SMK by combining knowledge of students, context, and pedagogical knowledge. Moreover, researchers concluded that even if teachers have similar SMK, their PCK will be qualitatively different due to different contexts.

On the other hand, Kind (2009a) compared trainees in and out of the field and found that trainees, while teaching out of their field they teach more effectively. Hence, lack of CK triggers pre-service teachers to work hard and improve their teaching. Similarly, Jüttner et al. (2013) conducted quantitative research to measure PCK and CK of biology teachers and found a low but significant correlation between teachers' CK and PCK. Also, in a review on PCK in science education, Kind (2009b) mentioned the debate on the relation between CK and PCK. The review indicated no consensus on how they are related and how PCK interacts with CK. Hence, there is a great need to determine how CK impacts their practical knowledge for teaching, namely PCK. The relationship between CK and PCK needs further research (Käpylä et al., 2009).

Furthermore, PCK literature calls for research using new methods in addition to interview, observation, Content representation (CoRe), and Pedagogical and Professional-experience Repertoires (PaP-eRs) to capture teachers' PCK while teaching (Abell, 2008). Also, in a recent book chapter, Henze and Van Driel (2015) mentioned that there have been studies to relate teachers' verbal articulation of PCK to actual classroom behavior; however, the relationship between teachers' PCK as investigated through interview and their teaching practice, is not straightforward. Henze and Van Driel (2015) proposed an option as utilizing stimulated recall interviews as a way of gaining a point of view regarding the knowledge that teachers use during the enactment of their instruction; hence "teachers obviously cannot think aloud while teaching, stimulated recall is a technique that asks teachers to comment on a video of teaching. The idea is not to ask teachers to justify what they did, but to reconstruct their thinking while they were teaching." (Henze & Van Driel, 2015, p.132) In the current study, a video stimulated recall interview was used to lead pre-service teachers to think aloud pertained to their classroom teaching and access the relationship between pre-service teachers' PCK and CK.

PCK development is an ongoing process, and the first step for PCK development is the pre-service teacher education level. During teacher education programs, pre-service teachers are prepared for their entire careers as teachers. They gain foundational knowledge and skills that will facilitate the development of their PCK during the teaching profession (Korthagen et al., 2006). One of the prevailing factors contributing to teachers' PCK development is science CK (Nilsson, 2008; Park & Oliver, 2008; Van Driel et al., 1998). Many in-service and pre-service teachers do not have adequate science CK about their teaching subject (Abell, 2007; McConnell et al., 2013). This lack of understanding of CK prevents them from properly planning and enacting their instruction (Tepner & Witner, 2011). However, it can be changed "...if pre-service teachers were offered meaningful ways of defining, assessing and explicitly developing PCK" (Nilsson & Loughran, 2012, p.700). As it was known, pre-service teachers have little or lack PCK (Magnusson et al., 1999; Van Driel et al. 1998) due to lack of teaching experience compared to experienced teachers (Nilsson, 2008). On the other hand, reflection is a crucial factor for pre-service teachers to develop teaching skills in their teaching practice and take more responsibility for their actions (Magnusson et al., 1999; Nilsson, 2008; Park & Oliver, 2008). In this respect, video stimulated recall interviews were a powerful method to explore teachers/pre-service teachers' knowledge of teaching (Malva et al., 2021). The powerful side of the present study is to collect data in the real classroom environment and give a chance to pre-service teachers to analyze, observe and reflect on their own classroom experiences via video stimulated recall interviews.

Although there have been large scale correlational studies investigating the relationship between teachers' CK and PCK with each other and with teaching practice (Kaya, 2009; Jüttner et al. 2013; Tepner & Dolly, 2014), little is known about how teachers' knowledge about a science topic (CK) impacts their teaching (PCK) in qualitative nature (Şen et al. 2018). Furthermore, there is a need to investigate the relationship between pre-service teachers' CK and PCK while transforming their CK into a real classroom environment (Kaya, 2009).

Therefore, this study aims to investigate the interaction between pre-service chemistry teachers' PCK and CK while teaching electrochemistry. The research question of the current study is:

How do pre-service chemistry teachers' CK and PCK, including STO, KoL, KoIS, KoAs, and KoC interact while teaching electrochemistry?

4. Methodology

4.1. Research Design

In this study, a qualitative multiple case study was conducted to gain a more holistic understanding of how pre-service teachers' PCK interacts with CK while teaching electrochemistry. Yin (2003) explained multiple case study as analyzing the data within each situation and across different situations. Baxter and Jack (2008) mentioned that researchers utilized multiple case study to understand the similarities and differences between the cases. In this study, two pre-service teachers enrolled in a science teaching experience course during one semester in a teacher education program comprised the case. According to qualitative research, action can best be interpreted and comprehended when observed in the natural setting (Bogdan & Biklen, 1998; Marshall & Rossman, 2006). The purpose of the study is to examine the interaction of pre-service teachers' CK and PCK. Participants were two pre-service chemistry teachers. One of them had high CK, and the other had low CK. So, two pre-service teachers can be described as multiple case study.

4.2 Participants

Purposeful sampling was used to select the participants (Merriam, 1998) in this study. In other words, we selected pre-service teachers whom we can learn most to gain insight pertained to the topic. Two phases were processed to choose the participants that the most can be learned. First, electrochemistry content test was conducted on 16 pre-service chemistry teachers. Then, cooperating high school and mentors were assigned for pre-service teachers. This research was conducted through the practice teaching course. During this course, pre-service teachers are supposed to experience teaching practice both at the faculty of education and the cooperating high school. Based on the grades taken from the electrochemistry content test and collaboration of mentors at the cooperating high school, two pre-service chemistry teachers were selected one with low CK (Defne) and one with high CK (Zeynep). The pre-service teachers were given pseudonyms: Zeynep and Defne. Two of them were in their last semester of a 5-year chemistry teacher education program that offers a master's degree without a thesis. Both had a similar background in terms of coursework. Before the practice teaching in science education course, both of them completed the courses including subject matter courses (e.g., general chemistry and organic chemistry), pedagogical courses (e.g., development and learning) and subject-specific pedagogical courses (e.g., methods of science teaching and instructional technology and material development). At the study time, Zeynep and Defne had CGPAs of 2.86 and 2.30 (of 4.00), respectively. Both pre-service teachers went to the same cooperating high school for their teaching experiences. Considering CK, Defne was coded as having low CK due to lack of her knowledge in concentration cell and electrolytic cells topics. On the other hand, Zeynep was coded as having high CK due to adequate CK in galvanic cell, concentration cell, and electrolytic cells topics.

4.3 Data Collection and Data Sources

PCK construct is complex and has internal nature, so it is comprised of what a teacher knows, what a teacher enacts during instruction, and the underlying reasons of instructional decisions; hence PCK cannot be identified using merely one type of data such as observation or interview (Baxter & Lederman, 1999). To investigate how pre-service teachers' PCK and CK interacted while teaching electrochemistry, data were collected via CoRe, semi-structured interviews and video stimulated recall interviews and observation. Data collection timeline was presented in Figure 1.

Figure 1

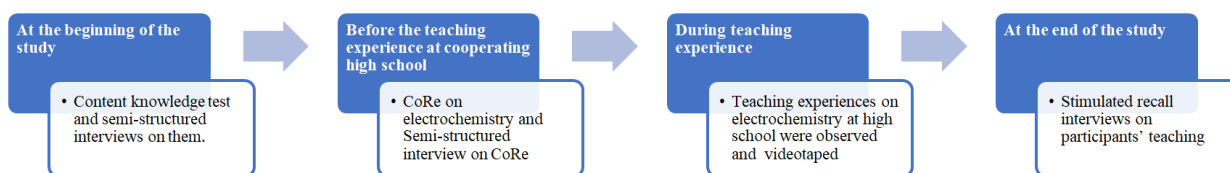
Data collection timeline*4.3.1. Content knowledge test*

Electrochemistry content test comprised of fifteen questions, including open-ended questions, true-false items, and fill in the blank types of questions. This test aimed twofold: to investigate pre-service teachers' understanding of electrochemistry qualitatively rather than quantitatively and to select pre-service teachers with high and low CK among the participants in the study. The content test was developed utilizing the related literature (Acar & Tarhan, 2007; Garnett & Treagust, 1992; Huddle et al., 2000; O' Grady-Morris, 2008; Ogude & Bradley, 1994; 1996; Sanger & Greenbowe, 1997a; 1997b). The questions were determined by taking into account the most common misconceptions teachers and pre-service teachers have on electrochemistry and the objectives presented in the 11th- grade chemistry curriculum in Turkey. The electrochemistry content test focused on the main concepts in electrochemistry: redox reactions, galvanic cells, standard hydrogen electrode, concentration cells, electrolytic cells, electrolysis. In addition to main concepts of electrochemistry, daily life applications of electrochemistry and questions that required algorithmic calculations were also included. (see some examples of test items in Appendix A) Regarding internal validity, the electrochemistry content test and table of specifications of this test were sent to five experts studying chemistry education. All the experts examined the questions and sent back their feedback. In the light of experts' feedback, the electrochemistry content test was revised and took its final form. Before the main study, CK test was conducted with two pre-service teachers to test face validity.

4.3.2. Content Representation (CoRe)

CoRe is a kind of form that represents pre-service and in-service teachers' PCK as "it [CoRe] links the how, why, and what of the content to be taught with what they agree to be important in shaping students' learning and teachers' teaching" (Loughran et al., 2012, p.17). CoRe is a methodological tool utilized to illustrate a teacher's PCK concerning a particular science topic based on recognizing the big ideas (Aydin et al., 2013). The horizontal column of the CoRe includes big ideas that teachers see as important to learn for students, and the vertical column includes specific information or prompts regarding big ideas that impact teachers' instruction.

In this study, CoRe was used as a lesson planning format for their instruction at cooperating high school. We also utilized CoRe to identify the interaction between pre-service teachers' PCK and CK. Since the present study was conducted with pre-service teachers enrolled in a practice teaching course, the revised form of CoRe (Aydin et al., 2013) was used in this study (see Appendix B). Before teaching, pre-service chemistry teachers prepared a CoRe regarding the electrochemistry topic for teaching for four hours during two weeks.

4.3.3. Interviews

There were different types of interviews conducted in this study: CK interview, CoRe interview and video stimulated recall interview. Detailed information regarding the interviews was presented in Table 1.

Table 1
Detailed information about interviews conducted

Types of interviews	Purpose of the interview and method	Time
Content knowledge interview	Purpose: To gain detailed knowledge about pre-service chemistry teachers' electrochemistry CK and to clarify the responses to questions at the electrochemistry content test Method: Semi-structured interview	After conducting the electrochemistry content test. It took between 30-40 minutes.
CoRe Interview	Purpose: To delve into the underlying reasons of pre-service teachers' planning and teaching. Also, participants were asked about their PCK and how PCK interacted their CK during the planning. Method: semi-structured interview	After participants prepared the CoRe. It took about 80-90 minutes.
Interview on their teaching (video stimulated recall interview)	Purpose: to gain insight into why pre-service teachers chose to enact and teach in certain ways, and how their PCK and CK interacted during their teaching Method: stimulated recall interview using video recordings	After enacting their instruction. For each lesson, the interview took approximately 60 minutes.

CK interview aimed to obtain detailed information regarding pre-service teachers' electrochemistry CK. After pre-service teachers' responses to the electrochemistry content test were reviewed, the interview questions were prepared. As mentioned in the CK test part, the test included fifteen questions that focused on redox reactions, galvanic cell, concentration cell, standard hydrogen electrode (SHE), electrolytic cell and concepts included in electrochemistry topic. During the interview, the missing or nebulous part of the pre-service teachers' responses in the electrochemistry content test were asked to clarify their understanding of electrochemistry concepts. CK interview was conducted after pre-service teachers' responses to the electrochemistry content test were reviewed, and two pre-service teachers were selected. The interviews lasted 30-40 minutes approximately for each pre-service teacher.

Regarding the CoRe interview, semi-structured interviews were conducted after the pre-service teachers prepared their CoRes on electrochemistry. this interview aimed to gain insight into pre-service teachers' reasoning about their instructional decision regarding their instruction and planning. Interview questions were prepared based on the CoRe developed by pre-service chemistry teachers. For instance, pre-service teacher wrote big ideas related to her instruction in the Core, during the interview it was asked as "How did you determine your big ideas?" or pre-service teacher mentioned in her CoRe that she would use informal questioning as formative assessment so it was asked the reasons of her preferences to use informal questioning.

Stimulated recall interviews allow teachers to clarify decision-making processes associated with their teaching practice (Dempsey, 2010; Nguyen et al., 2013). Jensen and Winitzky (2002) mentioned that stimulated recall interviews provided far more insight to elicit pre-service teachers' conceptions on their teaching and led pre-service teachers to reflect their views on their practice. Stimulated recall interviews have been used in the growing number of studies to gain insightful and useful data and facilitate pre-service teachers' and teachers' learning from their own teaching experiences (Freitas et al., 2004; Jensen & Winitzky, 2002; Lutovac et al., 2015; Nilsson, 2008; Schepens et al., 2007; Stough, 2001). Hence, a video stimulated recall interview was chosen as the primary data source for this study to enhance pre-service teachers' reflections about their instruction and examine the knowledge bases interaction, namely PCK and CK interaction. Video stimulated recall interview gave pre-service teachers a chance to view themselves while teaching and helped them recall their thoughts of instructional events that occurred during their instruction; hence this led them to make explicit their thinking and underlying reasons for teaching practice. During their electrochemistry teaching at high school, all their instructions were videotaped with the permission of pre-service teachers. After pre-service teachers completed their

teaching, their reflections and instructional decisions were elicited through an interview while watching their video recordings in the classroom with the researcher. During the interview, as it was advised (Nguyen et al. 2013; Dempsey, 2010) interview protocol was used the first author of the study developed that after watching four-hour instruction and identifying all the important points in the instruction in terms of PCK components and, interaction between CK and PCK for each pre-service teacher specially. Several examples for the interview questions are : “Why did you choose this (e.g., 5E [engagement, exploration, explanation, elaboration, and evaluation] learning cycle) teaching strategy in your instruction? “Why did you prefer to use this analogy/representation/ animation (e.g., sea-level analogy) in your instruction?” “Why did you refer chemical equilibrium during your instruction? How did you improve your students’ understanding of electrochemistry?” “Why did you emphasize the misconception regarding the identification of anode and cathode in galvanic cells while teaching electrochemistry?”. All the interviews were recorded with the permission of pre-service teachers using a digital voice recorder and transcribed verbatim.

4.3.4. Observation and field notes

Observation has a crucial role in qualitative studies and is used to explore complex interactions in natural field settings (Marshall & Rossman, 2006; Merriam, 1998). Observation was one of the main data sources for capturing pre-service teachers’ PCK and the interaction between PCK and CK while teaching electrochemistry in a real classroom environment in a high school. During the observation, the first author took field notes about what is going on in the classroom. The field notes are comprised of what the researcher hears, sees, experiences and thinks during the observation (Bogdan & Biklen, 1998). On the other hand, video recordings of classroom lessons allow researchers to capture the events in more detail and analyze the complex interaction that occurred during the lesson (Stigler et al., 2000). All teaching practices of pre-service teachers were video recorded. For each pre-service teacher, their teaching on electrochemistry was observed and recorded during four lessons with the permission of the pre-service teachers and teachers at the high school. In addition, video recordings can be paused or watched again and used for video stimulated recall interviews. While preparing stimulated recall interview questions, two researchers watched one hour of video recordings of pre-service teachers’ instruction and determined the crucial excerpts of the instruction independently and, discussed and reached consensus.

4.4. Data Analysis

The content test was composed of open-ended questions, true-false items and fill in the blank types of questions. The responses for the open-ended questions were categorized as scientifically correct, partially correct, incorrect and no response. The correct answer should include a depth understanding of the topic and the relationship between the concepts of the topic. A partially correct answer refers to the response containing some information but including misconceptions or inaccurate information. Incorrect response means the response is inadequate contains misconceptions or irrelevant information. No response is the area of answer that was left blank. The coding procedure and result of CK test analysis for participants of this study were provided in Table 2. After pre-service teachers’ responses to the electrochemistry content test were coded as separate cases, inductive coding was used to sort the pre-service teachers in terms of their level of CK. We used cross-case analysis in this inductive coding. We proposed two codes during the inductive coding: high and low CK based on their knowledge of electrochemistry topic.

Table 2

Result of content knowledge test analysis for participants

Content	Zeynep (High content knowledge)	Defne (Low Content Knowledge)
Redox reactions	Scientifically correct	Scientifically correct
Galvanic cells	Scientifically correct	Partially correct
Standard hydrogen Electrode	Scientifically correct	Partially correct
Concentration cells	Scientifically correct	Incorrect
Electrolytic cells	Partially correct	Incorrect
Electrolysis	Partially correct	Incorrect

In this study, pre-service chemistry teachers' PCK was analyzed deductively based on the Magnusson et al. (1999) PCK model.

Data regarding interactions between CK and PCK was analyzed inductively. Research studies (Käpylä et al., 2009; Park & Chen, 2012) were examined for inductive analysis. After coding the pre-service teachers' PCK and CK, two researchers coded all the interactions detected in the data sources but especially in the data collected by video stimulated recall interviews. In this way, Table 3 was formed including categories and examples. Considering this categorization, PCK and CK of pre-service teachers were presented and compared and contrasted to identify any difference between pre-service teachers in terms of the interaction of PCK and CK. Cross-case analysis indicated that the interaction between PCK components and CK were differentiated in some components regarding the CK level of pre-service teachers.

Table 3

Categories for analyzing data and their explanations

PCK component interacted with CK	Explanation
CK-STO interaction	If pre-service teacher used his/her CK to determine his/her goals and purposes for science teaching.
CK- KoL interaction	If pre-service teacher used his/her CK to identify and remedy students' difficulties and misconceptions.
	If pre-service teacher used his/her CK to identify students' prerequisite knowledge.
CK - KoIS interaction	If pre-service teacher chose appropriate/ inappropriate subject-specific strategy and effective usage of this strategy based on his/her CK.
	If pre-service teacher chose appropriate/inappropriate topic-specific instructional strategy in terms of representations and activities and effective usage of this strategy based on his/her CK.
CK- KoC interaction	If pre-service teacher made changes in curriculum utilizing her/his CK
	If pre-service teacher made vertical or/and horizontal relations to use what students know about the topic from previous courses or will learn in next courses at the same and different grades during his/her instruction based on his/her CK.
	If pre-service teacher changed the sequence the order of teaching utilizing his/her CK
	If pre-service teacher associated the concept with other disciplines utilizing his/her CK.
CK- KoAs interaction	If pre-service teacher determined objectives from curriculum utilizing his/her CK.
	If pre-service teacher determined the concepts that are important to assess or not utilizing his/her CK (what to assess)
	If pre-service teacher determined appropriate/inappropriate assessment methods to assess students' understanding or prior knowledge based on his/ her CK (how to assess)

For the trustworthiness of the study, two researchers coded the data independently. To increase the reliability of the procedures that the researchers have gone through, we compared and contrasted two coders' coding by the use of Miles and Huberman (1994) formula. Intercoder

agreement was greater than .80 which is the accepted value set by Miles and Huberman (1994). In case of the conflicts, further discussions were held to resolve them. The credibility of the study was also increased by the use of triangulation of sources and investigator triangulation, member checking, peer debriefing and adequate engagement in data collection.

5. Findings

5.1. Interactions between CK and STO

Pre-service teachers' science teaching orientations were almost similar regardless of their CK. In the pre-interview, both participants mentioned their goals for teaching chemistry to develop students' understanding of the relation between daily life and chemistry, to lead students develop a positive attitude towards science by understanding how science works and to prepare students for the university entrance exam. Related to teaching goals, Defne mentioned that:

Chemistry is a piece of science, and to understand the nature of science, students should learn chemistry. I think teaching chemistry is a way of making students love science.... Also, chemistry is everywhere in our life. For instance,, we drink water each day, and water is part of chemistry. Therefore, to understand meaningful what is happening in our lives, chemistry should be learned. Himm.. I think every student should have a certain amount of knowledge pertained to chemistry, physics, and biology because they may be interested in science in the future. **(CoRe Interview)**

Similarly, Zeynep emphasized her goals for teaching chemistry as following:

First, I would like to prepare students for life. There are many unknown things around us, there is a sense of wonder in human nature, so as humans, we try to understand and make sense of what is happening around the world. Chemistry is essential to do this, not only to understand the nature of the world but also the universe. One of my main purposes is to make students love science and use science to explain the events in their daily life. In this way, they would be more aware of around them. Students should know chemistry to improve themselves and to be scientifically literate citizens (CoRe Interview)

Also, their goals for teaching electrochemistry were very similar. They still stated their goals as preparing students for the university entrance exam and helping students understand daily life events due to the application of electrochemistry as batteries and electroplating. Although they mentioned their ideal goals during the interview, their instruction indicated that they mainly concentrated on providing the main concepts to students by empowering their instruction with daily life applications of the topic. For instance, in Zeynep's instruction she presented videos regarding electroplating and electrolysis of sodium chloride solution in terms of commercial applications of electrolytic cells. Moreover, their peripheral goal was to lead students to develop a positive attitude towards science teaching. For example, during Defne's instruction, she emphasized how science works. At the beginning of her instruction she explained the history of electrochemistry and indicated the tentativeness aspect of nature of science by giving examples from batteries.

Regarding the role of student and teacher, CK partly influenced science teaching orientation of pre-service teachers. For Defne's case, in galvanic cell, she constructed her instruction involving demonstration, analogy and animation, so she tried to involve students in class and keep them active in teaching also, she created a class environment that gives a chance for discussion. However, she tended to talk more in sub-topics with less CK, namely concentration and electrolytic cell, and students had a passive role. For Zeynep's case, similar to Defne, she enriched her instruction with discussion, demonstration, animation, analogy, and videos to keep students active. During the interview, she explained the role of her CK on her role of a teacher:

I know the basic concepts of electrochemistry, but in addition to this, I know the nature of topic, history and daily life applications of electrochemistry, so I chose discussion method and tried to participate the students actively into the instruction **(Stimulated recall interview)**

In conclusion, both of the participants mentioned goals as connecting scientific knowledge and daily life in the interview, and they indicated their teaching goal as transmitting the science topic to students empowering with daily life applications during their instruction, even though they had different levels of CK. However, their responses indicated minor differences compatible with their CK level regarding the role of teacher and student.

5.2. Interaction between CK and Knowledge of Learner

Participants in this study were aware of the prerequisite concepts: chemical reactions, redox reactions, solutions, and chemical equilibrium. Zeynep stated that "...without knowing the redox reactions, students cannot grasp working principles of both galvanic and electrolytic cells" (**CoRe interview**).

Regarding misconceptions, Defne and Zeynep possessed partial knowledge regarding students' misconceptions and difficulties about electrochemistry through reading the related literature and self-experiences. However, they differentiated in one point: while Zeynep was aware of the misconception and difficulties related to all sub-topics of electrochemistry, Defne was mainly aware of the misconceptions and difficulties regarding galvanic cell in parallel with their CK. Moreover, her experiences as a student influenced her knowledge of learner in the context of galvanic cells. As it was observed during the instructions, Defne generally emphasized the misconceptions that she had as a student. For instance, she stated that she had thought that "...Salt bridge seems like a bridge between two half-cells so to complete the circuit electron moves through salt bridge so I think there may be some students think like me" (**Stimulated recall interview**). As mentioned before, although Defne had adequate CK regarding galvanic cell, she had conceptual shortages in terms of electrolytic cell and concentration cell so she ignored the misconceptions regarding electrolytic cell and concentration cell due to lack of knowledge in these topics.

On the other hand, Zeynep was more aware of the misconceptions but she didn't emphasize the misconceptions during her instruction as Defne. For instance, although she knew that standard hydrogen electrode was chosen arbitrarily and the zero value of E^0 was not due to its chemical properties as CK, during the instruction, she ignored that students might have difficulty in understanding standard hydrogen electrode (**Field note**). During the interview, she stated that "I generally know the possible misconceptions and difficulties from articles but in real classroom environment I sometimes could not recognize this misconception due to lack of teaching experience" so having adequate CK on a topic doesn't guarantee to utilize this to identify students' understanding.

Defne made correct explanations rather than probing the underlying reasons of students' ideas to eliminate misconceptions detected during the instruction. In other words, her descriptions could not move beyond superficial explanations. She tried to eliminate misconceptions rarely using instructional strategies such as animation or analogy. For instance, she stated that in the past, she had thought that the standard hydrogen reduction potential value is zero due to its chemical properties so she needed to emphasize that the standard hydrogen electrode was randomly selected and just a reference point during the instruction. In addition to this scientific explanation, she utilized analogy to make this more understandable for students. But sometimes, she missed the misconceptions and difficulties students might have. For instance, while explaining galvanic cell, she asked students the direction of electron flow in galvanic cell, and one student answered as "from positive charge to negative charge" then Defne corrected student's answer as from anode to cathode (**Field note**). After instruction, when we asked Defne's view on the student's answer in the interview, she stated that she could not understand why students said like this and moved on to the other topic. In the physics course, students learned that electric current flows from positive to negative charge. Also, the direction of electric current and electron flow is reverse. In chemistry, electron flows from anode, negative charge, to cathode, positive charge. Due to the lack of CK in chemistry and physics in terms of determining the charge of electrodes and the link between

physics and chemistry, she could not diagnose the difficulty students have in understanding the direction of electron flow. Table 4 indicated the summary of results regarding the interaction between knowledge of learner and content knowledge for teaching electrochemistry for both pre-service chemistry teachers.

Table 4

The interaction between knowledge of learner and content knowledge teaching electrochemistry

<i>Defne's KoL</i>	<i>Content Knowledge</i>
Prerequisite knowledge	Defne knows the prerequisite knowledge to make links within electrochemistry and links between electrochemistry and other topics.
Misconceptions and difficulties	Defne was mainly aware of misconceptions and difficulties regarding galvanic cell in parallel with her content knowledge. She ignored the misconceptions regarding electrolytic cell and concentration cell due to lack of knowledge in these topics. Defne emphasized the misconceptions that she had as a student in previous.
<i>Zeynep's KoL</i>	<i>Content Knowledge</i>
Prerequisite knowledge	Zeynep knows the prerequisite knowledge to make links within electrochemistry and links between electrochemistry and other topics.
Misconceptions and difficulties	Zeynep was aware of the misconception and difficulties related to the all-sub-topics of electrochemistry. Zeynep sometimes did not emphasize misconceptions, although she knew the content and was aware of the misconception during instruction.

5.3. Interaction between CK and Knowledge of Instructional Strategy

Pre-service teachers in this study were knowledgeable and familiar with subject-specific strategies for teaching science as 5E learning cycle, conceptual change or inquiry due to courses taken during the teacher education program. But, on the other hand, they had difficulty implementing these strategies effectively. For instance, Defne chose 5E learning cycle instructional method. During the interview, she explained the underlying reason of 5E learning cycle method selection as:

R: How did you decide on your teaching method?

Defne: sure..I know the content of the topic [electrochemistry], so I said 5E learning cycle perfectly matches to nature of the topic [electrochemistry] and I chose to use 5E learning cycle" (**Stimulated recall interview**)

Furthermore, she could not use 5E learning cycle effectively in her teaching. Since, Defne had better CK on galvanic cells than electrolytic and concentration cells, she used the 5E learning cycle more effectively during the galvanic cell topic. However, she utilized lecturing preponderantly during concentration and electrolytic cells where she had low CK.

On the other hand, Zeynep didn't choose a subject-specific strategy for her instruction like Defne. Instead, she stated that she used discussion during her instruction but based on observations, her instruction could be labeled as teacher-centered instruction enriched with an analogy, animations, videos demonstrations and daily life application of the topics.

In her own words, she explained her instruction as:

"..The nature of the topic is very appropriate for discussion. Moreover, due to the nature of the topic, I could enrich the instruction with demonstration, videos, daily life applications, and animations, including microscopic level. Also, I could integrate NOS into electrochemistry, so my main aim was not to give the content as lecturing, I would prefer to make them experience in practice in addition to pure content."

Like Defne, Zeynep emphasized the role of the nature of the topic in her instruction strategy choice. Based on the observation data, Zeynep had adequate CK on galvanic, concentration and electrolytic cell, but she underlined the lack of teaching experience and classroom management skills prevented her from enacting instruction effectively. During the stimulated recall interview, she stated that

“...after watching my instructions, I realized that I could not enact the instruction via discussion effectively. I generally gave the answers just after the questions, so I could not create the discussion environment. Instead of this, I would try to understand why students responded the question in this way, what was the logic behind this or what led them think like this.” **(Stimulated recall interview)**

Hence, CK was not the only factor but influenced pre-service teachers' method choice.

Considering topic-specific strategies, pre-service teachers utilized representations, videos, animations, and analogies to make the content more understandable or eliminate students' difficulties or misconceptions related to the topic. Zeynep, who had better CK, used more topic-specific strategies than did her counterpart. While Zeynep was teaching concentration and electrolytic cells, she chose and used different representations appropriate to the sub-topic of electrochemistry utilizing her CK. For instance, she explained how we determine anode and cathode electrodes in concentration cells by drawing concentration cells (macroscopic representation) and writing half-reactions occurring in anode and cathode (symbolic representations). Another example could be given from electrolytic cell, she preferred to use video and animation while explaining the electrolysis of water and NaCl solution. During the stimulated recall interview, she explained that: “I know that electrolysis is a bit complicated and abstract concept, but I think electrolysis is important and we use it in our daily life so I chose an appropriate animation for indicating electrolysis of water in microscopic level” **(Stimulated recall interview)**. Thus, Zeynep's CK regarding the sub-topics of electrochemistry shaped her choice in terms of instructional strategy.

On the other hand, lack of CK influenced Defne's choices regarding topic-specific instructional strategies. For instance, while explaining galvanic cell, Defne preferred using animation and demonstration and verbal explanation; however, during the concentration cell, she just preferred verbal description due to her lack of knowledge. The interview excerpt indicates this situation as follows:

Researcher: Do you know how to identify anode and cathode in concentration cell?

Defne: the concentrated half-cell is cathode and the diluted half-cell is anode

R: why? Do you know the reason?

D: No, I read from the textbook, and I don't know the underlying reason.

R: during your instruction, you just said that and moved on? Why did you ask anything to students related to this topic?

D: I don't have deep knowledge of this subtopic, so I don't prefer to discuss it with the whole class.

R: you utilized representations such as animations, demonstrations while explaining galvanic cell, but why do you prefer lecturing while explaining concentration cell?

D: I think galvanic cell is the most crucial concept in this topic, the other cells, concentration and electrolytic cells are other formation of galvanic cell, but the main process is the same; I mean oxidation and reduction reactions occur. In concentration cell, the same process occurs, but the same electrodes are used but different concentrations.

R: could you evaluate your content knowledge in these subtopics?

D: If I compare my content knowledge in concentration cell and galvanic cell, I know less about the concentration cell.

R: Do you think this affects your choice in terms of instructional strategy? I mean, you prefer animation, demonstration etc. While explaining galvanic cell, but you prefer lecturing while explaining concentration cell?

D: maybe, I gave just explanations. **(Stimulated recall interview)**

In this situation, Defne's lack of CK tailored her instruction to provide a scientific explanation. In addition, she preferred to use lecturing to be on the safe side instead of involving student

activities as a discussion. Therefore, it could be concluded that pre-service teachers whose CK is better may have richer topic-specific strategies. Table 5 indicated the summary of the result regarding the interaction between pre-service teachers' content knowledge and knowledge of instructional strategies.

Table 5

The interaction between knowledge of instructional strategy and content knowledge for teaching electrochemistry

<i>Defne's Knowledge of Instructional strategy</i>	<i>Content Knowledge</i>
Subject specific instructional strategies	Defne preferred to use 5E learning cycle due to the nature of the topic and her orientation towards science teaching. Defne's content knowledge did not impact her subject-specific instructional strategy choice.
Topic specific instructional strategies	Defne utilized her content knowledge to choose appropriate activities and representations to make the concept more understandable, especially in the galvanic cell sub-topic. Lack of her content knowledge on electrolytic and concentration, she preferred just verbal explanations while teaching these topics. Due to her lack of content knowledge, she had difficulty constructing explanations to the learners' questions.
<i>Zeynep's Knowledge of Instructional strategy</i>	<i>Content Knowledge</i>
Subject specific instructional strategies	Zeynep did not use a subject-specific instructional strategy. She enacted a teacher-centered instruction enriched with animation, demonstration, analogy, and videos. Zeynep's adequate content knowledge did not directly impact her subject-specific instructional strategy choice.
Topic specific instructional strategies	Zeynep chose and used different representations and activities appropriate to all sub-topic of electrochemistry utilizing her content knowledge.

5.4. Interaction between CK and Knowledge of Curriculum

Both Defne and Zeynep determined the objectives to be addressed during the instruction from the National high school chemistry curriculum and chemistry high school textbook. But in addition to the objectives stated in these sources, they added objectives as mentioned in their CoRe. Examples from objectives written in Defne's and Zeynep's CoRe are as following: "Students should be able to understand working principles of galvanic cell with its components" (NME, 2012) (Zeynep & Defne) and "Students should be able to construct a cell system" (additional objective) (Zeynep).

During the interview, Defne explained how she determined these objectives for her instruction as:

"I did not copy all the objectives stated in the curriculum to my CoRe, I chose the objectives based on the content I would emphasize during my instruction, and I added a few objectives that were not stated in the curriculum" (CoRe Interview)

Similarly, Zeynep stated that

"I know electrochemistry, so while I was determining the objectives, I took into account the important concepts in electrochemistry that I thought a teacher should emphasize...exactly my content knowledge affected my preferences in terms of objectives to be addressed during the instruction" (CoRe Interview)

So, CK regarding the topic was influential in choosing the objectives that pre-service chose. Still, although their CK level was different, both of them chose similar objectives so it can be said that

their goals for teaching science had more effect on their objectives rather than their CK level. During the instruction just after electrolysis sub-topic, they provided examples pertained to commercial applications of chemistry namely purification and electroplating of metals. For instance, Defne provided just some explanations about the process of electroplating of metals and the importance of this process in our life. She mentioned that "For instance, iron will rust and iron rusting is an indication of corrosion. We can plate the surface of the iron with another metal that is resistant to corrosion to protect them corrosion." (**Field notes**). Zeynep also used videos to empower her explanations related to industrial applications of electrolysis and indicated video pertained to how electroplating process works especially electroplating a key with copper (**Field notes**).

Both pre-service teachers were aware of the curricular saliency, in other words, they knew the sequence of the topics in electrochemistry and the topics before and after the electrochemistry.

During their instruction, they followed high school chemistry textbooks closely. Hence, the CK level of pre-service doesn't have a remarkable effect on their curriculum knowledge regarding curricular saliency.

Concerning horizontal relations, Defne and Zeynep dominantly connected electrochemistry to the previous topic, chemical equilibrium but the quality of this horizontal relationship was different. While explaining concentration change on cell potential, Zeynep mentioned that Le Chatelier's principle can be used to predict the effect of concentration change on cell potential without using the Nerst equation (**Field notes**). Due to having adequate knowledge regarding electrochemistry and chemical equilibrium, she could establish a conceptual link between these topics. Furthermore, Zeynep utilized chemical equilibrium during the concentration cell sub-topic. She used her CK in chemical equilibrium to determine anode and cathode in concentration cell and explained as

"...concentration cell is composed of two half-cells including same electrodes differing only in concentrations so when the concentration of reactant in both half-cells are equal, concentration cell reaches equilibrium. In the less concentrated half-cell oxidation reaction occurs to increase the concentration so labeled as anode, in the more concentrated half-cell reduction reaction occurs to decrease the concentration and labeled as cathode" (**Stimulated recall interview**)

On the other hand, though Defne made similar horizontal relation as emphasizing chemical equilibrium during her instruction, the link between these two topics was superficial, it did not involve explanations resulting in conceptual understanding. For instance, while explaining the concentration change effect on cell potential and Nerst equation, she connected the topic with Le Chatelier's principle in chemical equilibrium. During her explanation, she utilized a chemical reaction and mentioned what the textbook stated in the classroom "If we increase the concentration of ion in the anode half-cell, the cell potential will decrease" (**Field notes**). She did not provide conceptual explanations or how we utilized chemical equilibrium to interpret the effect of concentration change on cell potential. After the instruction, during the interview, she stated that

"I don't know the underlying reason also, I could not understand exactly. I declared to students what I found in the textbook... If I evaluated my instruction, I could not relate chemical equilibrium and electrochemistry effectively, I should have blend these two topics more. This is because of my lack of content knowledge, but for the next instruction I will study more on these topics." (**Stimulated recall interview**)

Hence, the level of CK tailors the quality of knowledge of curriculum regarding horizontal curriculum. For example, because of Defne's lack of CK in terms of chemical equilibrium and electrochemistry, she tended to make superficial explanations and could not lead learners to understand conceptually rather she made learners memorize.

Although pre-service teachers had similar views on the core ideas and horizontal relations, they differed regarding vertical relations. Defne did not connect electrochemistry with the topics presented in the previous year or later years. On the other hand, Zeynep associated

electrochemistry with the types of reaction topics offered in 9th grade. She stated that “..at the 9th grade you are supposed to learn reactions types and redox reactions is one of them. Do you remember?” (**Field notes**) during her instruction. She aimed to remind the topic they have learned in previous years and make students aware of the topic in chemistry. Having adequate knowledge may have caused her to establish the link between these topics. The data revealed that the pre-service teacher with richer CK tends to have more knowledge of curriculum than the pre-service teacher with limited CK. Table 6 indicated the summary of the results pertained to the interaction between knowledge of curriculum and content knowledge while teaching electrochemistry.

Table 6

The interaction between knowledge of curriculum and content knowledge for teaching electrochemistry

<i>Defne's Knowledge of Curriculum</i>	<i>Content Knowledge</i>
Knowledge on goals and purposes	Defne determines the goals and objectives using content knowledge, but content knowledge level doesn't strongly affect this sub-component.
Vertical relation	Defne did not link electrochemistry with the topic from the previous year or later years.
Horizontal relation	Defne mentioned chemical equilibrium during her instruction, the link between these two topics was superficial, not including conceptual understanding.
Curricular saliency	Defne was aware of the curricular saliency and followed the high school chemistry textbook closely.
Connection to other disciplines	Defne could not link electrochemistry to physic while explaining how we determine anode and cathode in electrolytic cells due to lack of knowledge on both electrolytic cell and physics.
<i>Zeynep's Knowledge of Curriculum</i>	<i>Content Knowledge</i>
Knowledge on goals and purposes	Zeynep determines the essentail concepts and objectives using her electrochemistry content knowledge. Zeynep was aware of the misconception and difficulties related to the all-sub-topics of electrochemistry.
Vertical relation	Zeynep sometimes did not emphasize misconceptions, although she knew the content and was aware of the misconception during instruction.
Horizontal relation	Zeynep had adequate knowledge regarding electrochemistry and chemical equilibrium to establish a conceptual link between these topics.
Curricular saliency	Zeynep was aware of the curricular saliency and followed the high school chemistry textbook closely. Although Zeynep had adequate knowledge of electrochemistry, she did not attempt to change the topics.
Connection to other disciplines	Zeynep used the knowledge learned in physics to determine anode and cathode in electrolytic cells.

5.5. Interaction between CK and KoAs

Defne and Zeynep used informal questioning and homework to assess students' understanding during their instructions. The interaction between CK and the pre-service teacher's choice of assessing students' learning was detected regarding the quality and level of the questions asked during the assessment. For instance, Defne preferred to use informal questioning to assess electrolytic and galvanic cells; however, the level of questions differed. Although she tended to ask knowledge level questions or refrained from asking questions in electrolytic and concentration cell sub-topics, she asked higher cognitive level questions in galvanic cell. For instance, Defne asked

questions to identify students' understanding of salt bridges like "what is the function of salt bridge in galvanic cells?" "If we remove the salt bridge from the galvanic cell, will the cell continue to work?" "Why did cell stop working when we removed the salt bridge?" "Do electrons flow through the salt bridge?" (**Field notes**) These questions were aimed to move beyond the low-level cognitive questions.

On the other hand, due to her lack of knowledge, Defne generally ignored asking questions to assess students' understanding of electrolytic and concentration cell. She stated that "I could not use informal questioning so much in electrochemistry for the content that I don't know exactly [concentration and electrolytic cell], I hesitated asking questions because I don't know what I should say as response to students" (**Stimulated recall interview**). She thought that she had difficulty asking to follow up questions and responding to students' questions. The level of CK influenced Defne in terms of deciding how to assess students' understanding. During her instruction, Zeynep also used informal questioning for all subtopics of electrochemistry, namely galvanic, electrolytic, and concentration cell bu. Still, she sometimes had difficulty asking follow-up questions to assess students' understanding.

During the interview, we asked the reason for this situation, and Zeynep mentioned:

I don't have so much teaching experience, so I don't feel familiar with the real classroom environment, I feel anxious regarding failing to answer the questions of students correctly so when I take the correct response to the question, I move on to the next topic (**Stimulated recall interview**).

For summative assessment, Zeynep preferred to use interesting and researchable questions about how man-made diamond was produced. Her CK may have led her to assess students' understanding questions to push students to search and use their knowledge to explain new situations. Thus, the level of CK influences the quality of questions preferred to assess students' understanding. Table 7 indicated the results of interaction between content knowledge and knowledge of assessment for teaching electrochemistry.

Table 7

The interaction between knowledge of assesment and content knowledge for teaching electrochemistry

<i>Defne's Knowledge of Assessment</i>	<i>Content Knowledge</i>
How to assess	Defne used informal questioning and homework to assess students' understanding. The questions' qualities differed based on her content knowledge on the sub-topics of electrochemistry. Defne tended to ask knowledge level questions or refrained from asking questions in electrolytic and concentration cell sub-topics.
What to assess	Defne assessed predominantly conceptual understanding. Defne asked a few questions regarding NOS aspects.
<i>Zeynep's Knowledge of Assessment</i>	<i>Content Knowledge</i>
How to assess	Zeynep used informal questioning and homework to assess students' understanding. She asked questions regarding all sub-topics of electrochemistry. Zeynep used a researchable question as a homework.
What to assess	Zeynep assessed predominantly conceptual understanding.

6. Discussion

In the study, both of the pre-service teachers enacted teacher-centered instruction. Geddis (1993) and Friedrichsen et al. (2009) reported similar findings that pre-service teachers view teaching as transferring information to students, so their instruction is generally teacher-centered. Halim and Meerah (2002) explained this situation as pre-service teachers tend to focus on their teaching and "view teaching as telling and not representing content for pupils' learning" (p. 223). In terms of

determining goals and purposes for science teaching, both pre-service teachers selected similar goals for science teaching as preparing students to real-life by utilizing the application of electrochemistry as batteries and electroplating in the interviews. Still, in practice, they concentrated on providing the main concepts to students, although they have a different level of CK. It can be concluded that pre-service teachers' goals and purposes for science teaching were similar regardless of their CK level. This can be explained by the complex nature of science teaching orientation component. As mentioned in Şen et al. (2018), orientations towards science teaching are closely related to teachers' views on science and goals for teaching science, and also it is not topic-specific.

Concerning the knowledge of learner, pre-service teachers emphasized students' misconceptions regarding electrochemistry consistent with their CK level on electrochemistry. Pre-service teacher with high CK was more aware of the possible misconceptions than one with having low CK. For instance, the sub-topics as concentration and electrolytic cells that Defne's CK was inadequate, she was less aware of students' possible misconceptions as similar with findings of Hashweh (1987), Käpylä et al. (2009) and Halim and Meerah (2002). Halim and Meerah (2002) stated that when the teacher had more scientifically incorrect concepts about the topic, they could identify students' misconceptions less. Also, due to lack of CK, pre-service teachers had difficulty recognizing students' misconceptions, probably due to having similar misconceptions (Hashweh, 1987; Käpylä et al., 2009; Nakiboglu et al., 2010; Van Drivel et al. 2002). Furthermore, a pre-service teacher with low CK could not interpret students' questions or explanations correctly and sometimes her judgements were not appropriate, which may have reinforced misconceptions for students. This finding was also reported by Halim and Meerah (2002). In terms of prior knowledge, both of the pre-service teachers were aware of the prior knowledge, still they had difficulty using this prior knowledge while planning and enacting their instruction (Tabachnick & Zeichner, 1999). Tabachnick and Zeichner (1999) also stated that although pre-service teachers could elicit prior knowledge, they were unable to use this information to plan their instruction.

Regarding choosing subject-specific strategies, while pre-service teacher with low CK, Defne decided to use 5E learning cycle, the pre-service teacher with high CK chose a traditional instructional strategy enriched with activities and representations in the interviews. Still, in practice Defne used 5E learning cycle while teaching galvanic cell, and she turned to lecturing while explaining concentration and electrolytic cells. Hence, it can be concluded regarding subject-specific strategies, pre-service teachers were aware of subject-specific strategies, but in practice, both of them utilized lecturing; hence level of CK did not support pre-service teachers' choice on subject-specific instructional strategies. This result stands in line with Käpylä et al. (2009) and Ingber (2009). One reason for choosing a more student-centered instructional strategy by a pre-service teacher with weak CK might be to conceal lack of CK. When pre-service teachers' instruction was examined, both pre-service teachers used similar topic-specific strategies such as animation, analogy, videos, demonstration and drawings during their instruction but they differentiated in terms of effective usage of them parallel with their CK level. Also, pre-service teachers whose CK is better may have richer topic-specific strategies. The participant with solid CK tended to use discussion, while the other one with inadequate CK was reluctant to use student-centered approach due to the probability of not being able to respond to students' spontaneous questions. Hence, we claimed that pre-service teachers' knowledge of topic-specific strategies was positively affected by their level of CK, as mentioned in Şen et al. (2018). Regarding the topic-specific activities, they don't have so much experience and knowledge which demonstration or experiment is more appropriate for their teaching; most of the activities and representations used in their teaching were taken from the chemistry textbook (Nakiboglu et al., 2010). Based on the literature, the teachers who are more familiar with the topic have a tendency to talk less and choose activities that involve students more; however, the teachers who are less familiar with the topic are keen on more talking and prefer to use teacher-centered activities (Sanders et al., 1993). In

the current study, both of them gave opportunity to the students to get involved in the instruction in the subtopics they feel comfortable in terms of their CK level.

In this study, the level of CK impacted on pre-service teachers' knowledge of altering the curriculum, vertical and horizontal relations, and connections to other disciplines. The pre-service teacher with less CK had superficial knowledge on vertical and horizontal relations, and the link between other disciplines. Also, she was not able to connect the other topic that was supposed to associate with teaching electrochemistry conceptually. In other words, lack of CK prevented pre-service teachers from connecting between topics to improve students' understanding of electrochemistry. On the other hand, the pre-service teacher with more CK discussed the relations and tried to explain the connection conceptually. Although both of the participants determined the objectives covering the whole topic, during the instruction, they chose to teach the subtopics regarding their content level. The pre-service teacher with less CK on concentration and electrolytic cells did not emphasize these topics during her instruction. CK level impacted pre-service teachers' decision to determine the most important topics during their teaching and pre-service teachers sometimes ignored some of the concepts during their instruction parallel with inadequacies in their CK. One of the reasons might be to try to conceal weaker CK. This finding was consistent with the other studies in the literature as Käpylä et al. (2009), Kaya (2009) and Sanders et al. (1993). Käpylä et al. (2009) stated that pre-service teachers with strong CK emphasized most important concepts than their counterparts with weak CK. Hashweh (1987) also stated that "Teachers planned to teach the concepts used in the textbook however, they were also important additions and deletions partly affected by the teachers' prior SMK. Teachers tended to delete details they themselves could not remember" (p. 115). On the other hand, concerning the goals and objectives in the curriculum, there was no remarkable difference between pre-service teachers with different CK level. Both of them had general knowledge regarding the objectives presented in the national chemistry curriculum and did not have in-depth knowledge of limitations, warning and suggestions proposed by the curriculum. In addition, both of them mentioned additional objectives in their CoRe. Their instruction pertained to daily life applications of electrochemistry, historical development of electrochemistry, nature of science, and science process skills consistent with their goals for science teaching. This may be explained by the impact of courses in the teacher education programs. Grossman (1990) stated that disciplinary education is one of the important factors that contribute the construction of PCK. Hence, of course CK was important to determine the objectives for teaching but CK level did not have a remarkable effect on determining the objectives. Most probably, pre-service teachers' orientation to science teaching is more effective than CK level on decisions of pre-service teachers regarding the objectives and goals.

In this study, both of the pre-service teachers used traditional assessment methods informal questioning for diagnostic and formative assessment and homework for the summative assessment. This finding is consistent with Kaya (2009), who found that pre-service teachers with different CK level preferred to use traditional assessment methods. This may be due to lack of knowledge regarding alternative assessment methods and how to use them in practice. The level of CK influenced pre-service teachers' decisions on how to assess students' understanding regarding the quality and level of the questions asked during their teaching. Although both used informal questioning for diagnostic and formative assessment during their teaching, they preferred to ask higher cognitive level questions in the topics in which their CK is better. For instance, although Defne tended to ask knowledge level questions or refrained from asking questions in electrolytic and concentration cell sub-topics, she asked higher cognitive level questions in galvanic cell topic. This finding is consistent with Hashweh (1987) and Carlsen (1993). Both of these studies mentioned that while good CK led teachers to ask higher cognitive level questions, when teachers were unfamiliar to the topic, they tended to ask low cognitive level questions that required recalling information. Although pre-service teachers mentioned daily life

applications of chemistry and nature of science in addition to conceptual knowledge on electrochemistry, they predominantly assessed students' conceptual understanding.

7. Implications

This study has various implications pertained to pre-service teacher education and teacher education research studies. First, this study has implications for pre-service teacher education programs. Pre-service teacher education programs have a crucial role in improving pre-service teachers' PCK. During this program, pre-service teachers need support in terms of teaching ability and content knowledge on chemistry topics. Lack of CK is a kind of obstacle in pre-service teachers' PCK, so specialized courses might be designed that link CK and its impact on teaching practices in order to respond to pre-service teachers' needs and concerns regarding CK and PCK. Although chemistry teacher education programs have already courses related to almost each component of PCK namely "curriculum development and instruction in science education", "measurement and evaluation in science education" and "methods of science teaching I and II", these courses should be specialized integrating chemistry to this course and propose much more opportunities to pre-service teachers to practice this gained knowledge in real classroom environment. For instance, the course related to measurement and evaluation can be modified to provide pre-service teachers with both knowledge on alternative assessment methods and how to use them in practice. To sum up, taking into account the effect of CK on pre-service teachers' PCK, especially field education courses, should be reorganized in an integrated way with CK and PCK. This arrangement would significantly contribute to the development of pre-service teachers' PCK.

Moreover, the use of video stimulated recall interviews was effective on pre-service teachers' discovery of their PCK, which led them to be aware and contribute to their PCK development. Hence, utilizing the power of reflection on the professional development of pre-service teachers, video stimulated recall interview might be integrated into practice teaching courses. The relationship between CK and PCK needs further research, especially during classroom teaching to examine how experienced teachers use their CK in interaction with students, and how both CK and PCK interact. For pre-service teachers, how CK and PCK develop during the classroom teaching and how CK influences the development of PCK and how PCK influences the development of CK might be investigated. Such kinds of studies would contribute to teacher educators' understanding of how teaching and CK impact each other. Furthermore, this study was conducted with two pre-service chemistry teachers on the electrochemistry topic. It is recommended to conduct studies with qualified pre-service teachers and in-service teachers on various chemistry topics, more studies would enlighten the literature. Moreover, the results of the studies would provide useful information about the next steps taken for science teacher education programs.

Acknowledgements. This study is a part of the first author's doctoral dissertation.

References

- Abell, S.K. (2007). Research on science teacher knowledge In S.K. Abell & N.G. Lederman (Eds.), *Handbook of research on science education*. Lawrence Erlbaum.
- Abell, S. K. (2008). Twenty years later: Does pedagogical content knowledge remain a useful idea? *International Journal of Science Education*, 30(10), 1405-1416. <https://doi.org/10.1080/09500690802187041>
- Acar, B & Tarhan, L. (2007). Effect of cooperative learning strategies on students' understanding of concepts in electrochemistry. *International Journal of Science and Mathematics Education*, 5, 349-373. <https://doi.org/10.1007/s10763-006-9046-7>
- Aydin-Gunbatar, S., & Akin, F. N. (2022). Pre-service chemistry teachers' use of pedagogical transformation competence to develop topic-specific pedagogical content knowledge for planning to teach acid-base equilibrium. *Chemistry Education Research and Practice*, 23(1), 137-158. <https://doi.org/10.1039/D1RP00106j>

- Aydin, S., Demirdogen, B., Tarkin, A., Kutucu, E. S., Ekiz, B., Akin, F., et al. (2013). Providing a set of research-based practices to support preservice teachers' long-term professional development as learners of science teaching. *Science Education*, 97(6), 903 – 935. <https://doi.org/10.1002/sce.21080>
- Aydin, S., Friedrichsen, P. M., Boz, Y., & Hanuscin, D. L. (2014). Examination of the topic-specific nature of pedagogical content knowledge in teaching electrochemical cells and nuclear reactions. *Chemistry Education Research and Practice*, 15(4), 658-674. <https://doi.org/10.1039/C4RP00105B>
- Baxter, J. A. & Lederman, N. G. (1999). Assessment and measurement of pedagogical content knowledge. In: J. Gess-Newsome & N. G. Lederman (Eds.), *Examining pedagogical content knowledge* (pp. 147-161). Kluwer Academic Publishers.
- Baxter, P., & Jack, S. (2008). Qualitative case study methodology: Study design and implementation for novice researchers. *The Qualitative Report*, 13(4), 544-556.
- Bogdan R. C. & Biklen, S. K. (1998). *Qualitative research for education: An introduction to theory and methods* (3rd ed.). Allyn and Bacon.
- Boz, N. & Boz, Y. (2008). A qualitative case study of prospective chemistry teachers' knowledge about instructional strategies: Introducing Particulate Theory. *Journal of Science Teacher Education*, 19, 135-156. <https://doi.org/10.1007/s10972-007-9087-y>
- Carlsen, W. S. (1993). Teacher knowledge and discourse control: Quantitative evidence from novice biology teachers' classrooms. *Journal of Research in Science Teaching*, 30, 471-481. <https://doi.org/10.1002/tea.3660300506>
- Carlson, J., & Daehler, K. R. (2019). The refined consensus model of pedagogical content knowledge in science education. In A. Hume, R. Cooper, & A. Borowski (Eds.) *Repositioning pedagogical content knowledge in teachers' knowledge for teaching science* (pp. 77-94). Springer.
- Childs, A. & McNicholl, J. (2007). Investigating the relationship between subject content knowledge and pedagogical practice through the analysis of classroom discourse. *International Journal of Science Education*, 29(13), 1629-1653. <https://doi.org/10.1080/09500690601180817>
- Dempsey, N. P. (2010). Stimulated recall interviews in ethnography. *Qualitative Sociology*, 33, 349-367. <https://doi.org/10.1007/s11133-010-9157-x>
- De Jong, O., & Treagust, D. (2002). The teaching and learning of electrochemistry. In J. K. Gilbert, O. De Jong, R. Justi, D. F. Treagust & J. H. van Driel (Eds.), *Chemical Education: Towards research-based practice* (pp. 317-337). Kluwer Academic Publishers.
- Fischer, H.E., Borowski, A. & Tepner, O. (2012) Professional knowledge of science teachers. In B.J. Fraser, K. Tobin, & C. McRobbie, (Eds.) *Second international handbook of science education*. (pp 435- 448). Springer.
- Freitas, I.M., Jiménez, R., & Mellado, V. (2004). Solving physics problems: The conceptions and practice of an experienced teacher and an inexperienced teacher. *Research in Science Education*, 34, 113-133. <https://doi.org/10.1023/B:RISE.0000021000.61909.66>
- Friedrichsen, P., Abell, S., Pareja, E., Brown, P., Lankford, D., & Volkman, M. (2009). Does teaching experience matter? Examining biology teachers' prior knowledge for teaching in an alternative certification program. *Journal of Research in Science Teaching*, 46(4), 357-383. <https://doi.org/10.1002/tea.20283>
- Garnett, P.J., & Treagust, D.F. (1992b). Conceptual difficulties experienced by senior high school students of electrochemistry: Electrochemical (galvanic) and electrolytic cells. *Journal of Research in Science Teaching*, 29(10), 1079-1099. <https://doi.org/10.1002/tea.3660290204>
- Geddis, A. N. (1993). Transforming subject-matter knowledge: The role of pedagogical content knowledge in learning to reflect on teaching. *International Journal of Science Education*, 15(6), 673-683. <https://doi.org/10.1080/0950069930150605>
- Gess-Newsome, J. (1999). Pedagogical content knowledge: An introduction and orientation nature, sources and development of pedagogical content knowledge for science teaching, In J. Gess-Newsome & N. G. Lederman (Eds.). *Examining pedagogical content knowledge: The construct and its implications for science education* (pp.3-17). Kluwer.
- Gess-Newsome, J. (2015). A model of teacher professional knowledge and skill including PCK: Results of the thinking of the PCK summit. In A. Berry, P. Friedrichsen, & J. Loughran (Eds.), *Re-examining pedagogical content knowledge in science education* (pp. 28-41). Routledge.
- Goodnough, K. C., & Hung, W. (2008). Engaging teachers' pedagogical content knowledge: Adopting a nine-step problem-based learning model. *Interdisciplinary Journal of Problem-based Learning*, 2(2), 61-90.
- Grossman, P. (1990). *The making of a teacher*. Teachers College Press.

- Halim, L., & Meerah, S.M. (2002). Science trainee teachers' pedagogical content knowledge and its influence on physics teaching. *Research in Science and Technological Education*, 2(2), 215–225. <https://doi.org/10.1080/0263514022000030462>
- Hashweh, M. Z. (1987). Effects of subject matter knowledge in the teaching of biology and physics. *Teaching & Teacher Education*, 3(2), 109–120. [https://doi.org/10.1016/0742-051X\(87\)90012-6](https://doi.org/10.1016/0742-051X(87)90012-6)
- Hashweh, M.Z. (2005). Teacher pedagogical constructions: A reconfiguration of pedagogical content knowledge. *Teachers and Teaching: Theory and practice*, 11, 273–292. <https://doi.org/10.1080/13450600500105502>
- Henze, I. & Van Driel, J. H. (2015) Toward a More Comprehensive Way to Capture PCK in Its Complexity. In A. Berry, P. Friedrichsen & J. Loughran, (Ed) *Re-examining Pedagogical content knowledge in science education* (pp 120-134). Routledge.
- Huddle, P.A., White, M.D., & Rogers, F. (2000). Using a teaching model to correct known misconceptions in electrochemistry. *Journal of Chemical Education*, 77(1), 104–110. <https://doi.org/10.1021/ed077p104>
- Ingber, J. (2009). A comparison of teachers' pedagogical content knowledge while planning in and out of their science expertise [Unpublished doctoral dissertation]. Columbia University, NY, USA.
- Jensen, J.W. & Winitzky, N. (2002, February). *Exploring preservice teacher thinking: A comparison of five measures* [Paper presentation]. Annual Meeting of the American Association of Colleges for Teacher Education, New York.
- Jüttner, M., Boone, W., Park, S., & Neuhaus, B. J. (2013). Development and use of a test instrument to measure biology teachers' content knowledge (CK) and pedagogical content knowledge (PCK). *Educational Assessment, Evaluation and Accountability*, 25(1), 45–67. <https://doi.org/10.1007/s11092-013-9157-y>
- Kaya, O. N. (2009). The nature of relationships among the components of pedagogical content knowledge of pre-service science teachers: 'Ozone layer depletion' as an example. *International Journal of Science Education*, 31(7), 961–988. <https://doi.org/10.1080/09500690801911326>
- Kaya, Z., Kaya, O. N., Aydemir, S., & Ebenezer, J. (2021). Knowledge of student learning difficulties as a plausible conceptual change pathway between content knowledge and pedagogical content knowledge. *Research in Science Education*, 52, 691–723. <https://doi.org/10.1007/s11165-020-09971-5>
- Käpylä, M., Jussi-Pekka Heikkinen, J., & Asunta, T. (2009). Influence of content knowledge on pedagogical content knowledge: The case of teaching photosynthesis and plant growth. *International Journal of Science Education*, 31(10), 1395–1415. <https://doi.org/10.1080/09500690802082168>
- Kind, V. (2009a). 'A conflict in your head': An exploration of trainee science teachers' subject matter knowledge development and its impact on teacher self-confidence. *International Journal of Science Education*, 31(11), 1529–1562. <https://doi.org/10.1080/09500690802226062>
- Kind, V. (2009b). Pedagogical content knowledge in science education: Perspectives and potential for progress. *Studies in Science Education*, 45(2), 169–204. <https://doi.org/10.1080/03057260903142285>
- Korthagen, F., Loughran, J.J., & Russell, T. (2006). Developing fundamental principles for teacher education programs and practices, *Teaching and Teacher Education*, 22(8), 1020–1041. <https://doi.org/10.1016/j.tate.2006.04.022>
- Loughran, J., Berry, A., & Mulhall, P. (2012). *Understanding and Developing Science Teachers' Pedagogical Content Knowledge*. Sense Publishers.
- Lutovac, S., Kaasila, R. & Juuso, H. (2015). Video-stimulated recall as a facilitator of a pre-service teacher's reflection on teaching and post-teaching supervision discussion - A case study from Finland. *Journal of Education and Learning*, 4(3), 14–24.
- Magnusson, S., Krajcik, J., & Borke, H. (1999). Nature, sources and development of pedagogical content knowledge for science teaching. In J. Gess-Newsome & N. G. Lederman (Eds.), *Examining pedagogical content knowledge: The construct and its implications for science education* (pp. 95-132). Kluwer.
- Malva, L., Leijen, Ä., & Arcidiacono, F. (2021). Identifying teachers' general pedagogical knowledge: A video stimulated recall study. *Educational Studies*. <https://doi.org/10.1080/03055698.2021.1873738>
- Mapolelo, D. C. (1999). Do pre-service primary teachers who excel in mathematics become good mathematics teachers? *Teaching and Teacher Education*, 15, 715–725. [https://doi.org/10.1016/S0742-051X\(99\)00012-8](https://doi.org/10.1016/S0742-051X(99)00012-8)
- Marshall, C., & Rossman, G. B (2006). *Designing qualitative research* (4th ed.). Sage.
- Mavhunga, E., (2016). Transfer of the pedagogical transformation competence across chemistry topics. *Chemistry Education Research and Practice*, 17(4), 1081–1097. <https://doi.org/10.1039/C6RP00095A>

- McConnell, T. J., Parker, J.M., & Eberhardt, J. (2013). Assessing teachers' science content knowledge: a strategy for assessing depth of understanding. *Journal of Science Teacher Education*, 24(4), 717-743. <https://doi.org/10.1007/s10972-013-9342-3>
- Merriam, S. B. (1998). *Qualitative research and case study applications in education*. Jossey-Bass Publishers.
- Miles, M. B., & Huberman, A. M. (1994). *Qualitative data analysis: An expanded sourcebook*. Sage.
- Nakiboglu, C., Karakoc, O., & De Jong, O. (2010). Examining pre-service chemistry teachers' pedagogical content knowledge and influences of teacher course and practice school. *Journal of Science Education*, 11(2), 76-79.
- Nguyen, N., McFadden, A., Tangen, D., & Beutel, D. (2013) *Video-stimulated recall interviews in qualitative research*. Australian Association for Research in Education Annual Conference.
- Nilsson, P. (2008). Teaching for understanding: The complex nature of pedagogical content knowledge in pre-service education. *International Journal of Science Education*, 30(10), 1281-1299. <https://doi.org/10.1080/09500690802186993>
- Nilsson, P., & Loughran, J. (2012). Exploring the development of pre-service science elementary teachers' pedagogical content knowledge. *Journal of Science Teacher Education*, 23(7), 699-721. <https://doi.org/10.1007/s10972-011-9239-y>
- Ogude, A. N., & Bradley, J. D. (1994). Ionic conduction and electrical neutrality in operating electrochemical cells. *Journal of Chemical Education*, 71(1), 29-34. <https://doi.org/10.1021/ed071p29>
- Ogude, A. N., & Bradley, J. D. (1996). Electrode processes and aspects relating to cell EMF, current, and cell components in operating electrochemical cells. *Journal of Chemical Education*, 73(12), 1145-1149. <https://doi.org/10.1021/ed073p1145>
- Park, S. & Oliver, J. S. (2008). Revisiting the conceptualization of pedagogical content knowledge (PCK): PCK as a conceptual tool to understand teachers as professionals. *Research in Science Education*, 38, 261-284. <https://doi.org/10.1007/s11165-007-9049-6>
- Park, S., & Chen, Y. C. (2012). Mapping out the integration of the components of pedagogical content knowledge (PCK): Examples from high school biology classrooms. *Journal of Research in Science Teaching*, 49(7), 922-941. <https://doi.org/10.1002/tea.21022>
- Rollnick, M., Bennett, J., Rhemtula, M., Dharsey, N., & Ndlovu, T. (2008). The place of subject matter knowledge in pedagogical content knowledge: A case study of South African teachers teaching the amount of substance and chemical equilibrium. *International Journal of Science Education*, 30, 1365-1388. <https://doi.org/10.1080/09500690802187025>
- Rollnick, M., & Mavhunga, E. (2014). PCK of teaching electrochemistry in chemistry teachers: A case in Johannesburg, Gauteng Province, South Africa. *Educacion Quimica*, 25(3), 336-354. [https://doi.org/10.1016/S0187-893X\(14\)70551-8](https://doi.org/10.1016/S0187-893X(14)70551-8)
- Sæleset J. & Friedrichsen P., (2021). Pre-service science teachers' pedagogical content knowledge integration of students' understanding in science and instructional strategies. *Eurasia Journal of Mathematics, Science Technology Education*, 17(5), <https://doi.org/10.29333/ejmste/10859>
- Sande M. E., (2010), Pedagogical content knowledge and the gas laws: A multiple case study [Unpublished doctoral dissertation]. University of Minnesota, USA.
- Sanders, L. R., Borko, H., & Lockard, J. D. (1993). Secondary science teachers' knowledge base when teaching science courses in and out of their area of certification. *Journal of Research in Science Teaching*, 30, 723-736. <https://doi.org/10.1002/tea.3660300710>
- Sanger, M.J., & Greenbowe, T.J. (1997a). Students' misconceptions in electrochemistry: current flow in electrolyte solutions and the salt bridge. *Journal of Chemical Education*, 74(7), 819-823. <https://doi.org/10.1021/ed074p819>
- Sanger, M.J., & Greenbowe, T.J. (1997b). Common student misconceptions in electrochemistry: Galvanic, electrolytic, and concentration cells. *Journal of Research in Science Teaching*, 34(4), 377-398. [https://doi.org/10.1002/\(SICI\)1098-2736\(199704\)34:4<377::AID-TEA7>3.0.CO;2-O](https://doi.org/10.1002/(SICI)1098-2736(199704)34:4<377::AID-TEA7>3.0.CO;2-O)
- Schepens, A., Aelterman, A., & Van Keer, H. (2007). Studying learning processes of student teachers with stimulated recall interviews through changes in interactive cognitions. *Teaching and Teacher Education*, 23(4), 457-472. <https://doi.org/10.1016/j.tate.2006.12.014>
- Shulman, L. S. (1986). Those who understand: Knowledge growth in teaching. *Educational Researcher*, 15(2), 4-14. <https://doi.org/10.3102/0013189X015002004>
- Shulman, L. S. (1987). Knowledge and training: Foundations of the new reform. *Harvard Educational Review*, 57(1), 1-22. <https://doi.org/10.17763/haer.57.1.j463w79r56455411>

- Stigler, J. W., Gallimore, R. & Hiebert, J. (2000). Using video surveys to compare classrooms and teaching across cultures: Examples and lessons from the TIMSS video studies. *Educational Psychologist*, 35(2), 87-100. https://doi.org/10.1207/S15326985EP3502_3
- Stough, L. M. (2001). Using stimulated recall in classrooms observation and professional development [Paper presentation]. Annual Meeting of the American Educational Research Association, Seattle, WA.
- Şen, M., Öztekin, C., & Demirdöğen, B. (2018). Impact of content knowledge on pedagogical content knowledge in the context of cell division. *Journal of Science Teacher Education*, 29(2), 102-127. <https://doi.org/10.1080/1046560X.2018.1425819>
- Şen, M., Demirdöğen, B., & Öztekin, C. (2022). Interactions among topic-specific pedagogical content knowledge components for science teachers: The impact of content knowledge. *Journal of Science Teacher Education*. <https://doi.org/10.1080/1046560X.2021.2012630>
- Tabachnick, B.R., & Zeichner, K.M. (1999). Idea and action: Action research and the development of conceptual change teaching of science. *Science Education*, 83, 309-322. [https://doi.org/10.1002/\(SICI\)1098-237X\(199905\)83:3<309::AID-SCE3>3.0.CO;2-1](https://doi.org/10.1002/(SICI)1098-237X(199905)83:3<309::AID-SCE3>3.0.CO;2-1)
- Tamir, P. (1988). Subject matter and related pedagogical knowledge in teacher education. *Teaching and Teacher Education*, 4(2), 99-110. [https://doi.org/10.1016/0742-051X\(88\)90011-X](https://doi.org/10.1016/0742-051X(88)90011-X)
- Tepner, O. & Dollny, S. (2014). Measuring chemistry teachers' content knowledge: Is it correlated to pedagogical content knowledge. In C. Bruguere, A. Tiberghien and P. Clément (Eds.), *Topics and trends in current science education, 9th ESERA conference selected contributions* (pp. 243-254). European Science Education Research Association.
- Tepner, O. & Witner, S. (2011). *Comparison of pre-service and in-service teachers' CK and PCK in chemistry* [Paper presentation]. NARST, 3-6 April, Orlando, Florida, USA.
- Van Driel, J. H., De Jong, O., & Verloop, N. (2002). The development of preservice chemistry teachers' pedagogical content knowledge. *Science Education*, 86(4), 572-590. <https://doi.org/10.1002/sce.10010>
- Van Driel, J. H., Verloop, N., & de Vos, W. (1998). Developing science teachers' pedagogical content knowledge. *Journal of Research in Science Teaching*, 35(6), 673-695. [https://doi.org/10.1002/\(SICI\)1098-2736\(199808\)35:6<673::AID-TEA5>3.0.CO;2-J](https://doi.org/10.1002/(SICI)1098-2736(199808)35:6<673::AID-TEA5>3.0.CO;2-J)
- Yin, R. K. (2003). *Case study research: Design and methods*. Sage.

Appendix A. Sample Items From Electrochemistry Content Test

1. Please answer the following questions according to electrochemical cell drawn below.

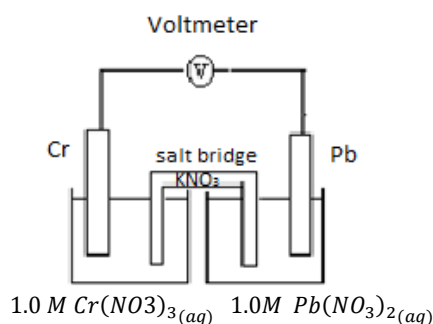

The salt bridge contains $KNO_3(aq)$

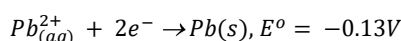
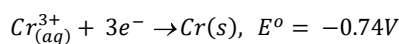

- Which electrode is the anode and which is the cathode? How would you determine which electrode is anode and which electrode is cathode? Please explain.
- Please write half- reactions occurring at anode and cathode, and overall cell reaction.
- What is the direction of electron flow in this cell? Please draw the route of electron flow on the cell above.
- When galvanic cell operates, does any change occur in mass of each electrode with time? Please explain.
- In which direction do anions and cations in the salt bridge ($KNO_3(aq)$) flow? Please draw the flow of ions using arrows.
- What would the value on the voltmeter be if the salt bridge were removed? (Increase, decrease, or no change). Please explain your answer.

2. Please answer the following questions according to electrochemical cell drawn below.

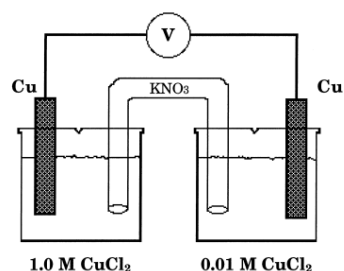

- How would you decide which electrode is the anode and which is the cathode?
- Could you please write the chemical reactions occurring at each electrode and overall cell reaction?
- If the concentration in the right cell was changed from 0.01 M $CuCl_2$ to 0.001 M $CuCl_2$, What would happen to E_{cell} ? (Increase, decrease, no change, etc.)
- When does this electrochemical cell stop working? Please explain your answer.

3. Why do batteries go dead?

4. Please state whether the explanations below are true or false by writing "T" for true and "F" for false.

- Standard reduction potentials can be measured independently without the use of other half-cell reactions with the known potentials.
- The fact that the E° for H_2 (1 atm)/ H^+ (1 M) is zero is somehow based on the chemistry of H^+ and H_2 .
- In electrolytic cell with identical electrodes connected to the battery, the same reactions will occur at both electrodes.
- Working principle of concentration cells is based on the concentration difference of electrolytes in anode and cathode half-cells.
- In a galvanic cell, anode is always on the left and cathode is always on the right.
- Electron can flow through the aqueous solution without assistance from the ions.
- Iron rusts when it contacts with both oxygen and water.

Appendix B. CoRe (Content Representation)

Name: LESSON PLANNING FORM

Chemistry Topic/Content Area:

Grade level	Curriculum Objectives to be addressed:		
Concept#1	Concept#2	Concept#3	

- What concepts/big ideas do you intend students to learn?
- What do you expect students to understand about this concept and be able to do as a result?
- Why is it important for students to learn this concept?
(Rationale)
- As a teacher, what should you know about this topic?
- What difficulties do students typically have about each concept/idea?
- What misconceptions do students typically have about each concept/idea?
- Which teaching strategy and what specific activities might be useful for helping students develop an understanding of the concept?
- In what ways would you assess students' understanding or confusion about this concept?

Formative
Assessment
Summative
Assessment

9. What materials/ equipment are needed to teach the lesson?